



# Flowtite Pipe Systems

Raw Water



**AMIA**TIT PIPE SYSTEMS

01	<b>1 Production Process</b> _____	3
02	<b>2 Product Advantages</b> _____	4
	Features & Benefits .....	4
03	<b>3 Certificates and Approvals</b> _____	4
04	<b>4 Quality Characteristics</b> _____	5
	<b>4.1</b> Raw Materials .....	5
	<b>4.2</b> Physical Properties .....	5
	<b>4.3</b> Finished Pipe Properties .....	5
	<b>4.4</b> Other Quality Characteristics .....	5
05	<b>5 Product Range</b> _____	6
	<b>5.1</b> Stiffness Classes .....	6
	<b>5.2</b> Pressure .....	6
	<b>5.3</b> Length .....	6
	<b>5.4</b> Hydro-Testing .....	6
	<b>5.5</b> Standard Pipe and Coupling Data Sheet .....	6
06	<b>6 Pipe Joining</b> _____	9
	<b>6.1</b> Double Bell Coupling (FPC) .....	9
	<b>6.2</b> Locked Joints .....	10
	<b>6.3</b> Other Joining Systems .....	10
07	<b>7 Accessories</b> _____	12
	<b>7.1</b> Segmented Bends .....	13
	<b>7.2</b> Segmented Reducers – Concentric – .....	15
	<b>7.3</b> Segmented Tees – Equal and Reduced – .....	16
	<b>7.4</b> Moulded Bends .....	31
	<b>7.5</b> Moulded Reducers – Concentric – .....	33
	<b>7.6</b> Moulded Tees – Equal and Reduced – .....	34
	<b>7.7</b> Wall Couplings .....	35
	<b>7.8</b> Fix Flanges – Type A .....	36
	<b>7.9</b> Fix Flanges – Type B .....	38
	<b>7.10</b> Blind Flanges .....	40
	<b>7.11</b> Loose Flanges and Collars .....	42
	<b>7.12</b> Wall Connection Pieces Type E .....	44
	<b>7.13</b> Wall Connection Pieces Type F .....	44
	<b>7.14</b> Wall Connection Pieces Type G .....	45
	<b>7.15</b> Short Section Pipes .....	45
	<b>7.16</b> Valve Chambers .....	46
08	<b>8 Local Approvals and Certificates</b> _____	47

# 1 Production Process

The basic raw materials used in the FLOWTITE pipe's manufacturing are resin, fibreglass and silica sand. Usually unsaturated polyester resins are used since they give good performance for raw water applications.

FLOWTITE pipes are manufactured using the continuous advancing mandrel process, which represents the state of the art in GRP pipe production. This process allows the use of continuous glass fibre reinforcements in the circumferential direction. For a pressure pipe or buried conduit, the principle stress is in the circumferential direction, thus incorporating continuous reinforcements in this direction yields a higher performing product at a lower cost. Using technology developed by material specialists, a very dense laminate is created that maximizes the contribution from three basic raw materials. Both continuous glass fibre rovings and choppable roving are incorporated for high hoop strength and axial reinforcement. A sand fortifier is used to provide increased stiffness by adding extra thickness, placed near the neutral axis in the core. With the FLOWTITE dual resin delivery system, the equipment has the capability of applying a special inner resin liner for severe corrosive applications while utilising a less costly resin for the structural and outer portion of the laminate.

Taking advantage of the winding process, other materials, such as a glass veil or polyester veil can be used to enhance the abrasion resistance and the finishing of the pipe.

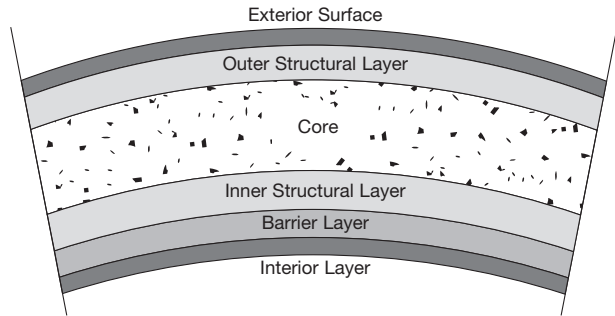

The figure above shows a typical cross section of a pipe laminate. This section, as well as the way of applying and placing different raw materials, can differ depending on the pipe application.

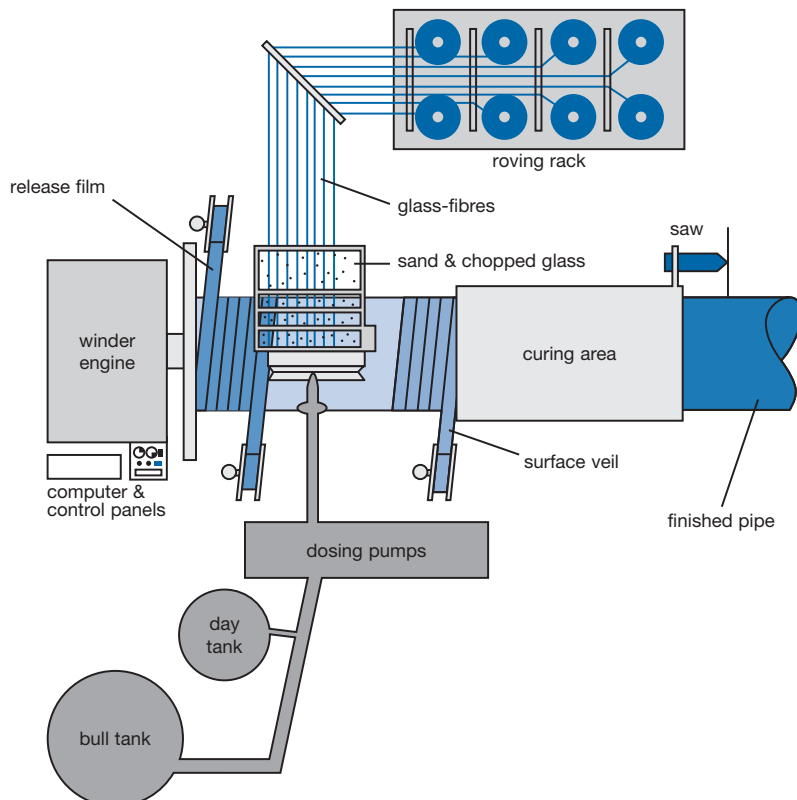

## 2 Product Advantages

FLOWTITE Technology has been able to bring a product to the market that can provide a low cost, long-term piping solution to customers around the world. The long list of features and benefits add up to provide the optimum installed and life cycle cost system.

### Features & Benefits

#### Corrosion-resistant

- Long, effective service-life materials
- No need for linings, coatings, cathodic protection, wraps or other forms of corrosion protection
- Low maintenance costs
- Hydraulic characteristics essentially constant over time

#### Light weight

(1/4 weight of ductile iron or steel; 1/10 weight of concrete)

- Low transport costs (nestable)
- Eliminates need for expensive pipe handling equipment

#### Long standard lengths

(up to 18 metres with individual lengths on request)

- Fewer joints reduce installation time
- More pipe per transport vehicle means lower delivery costs

#### Extremely smooth bore

- Low friction loss means less pumping energy needed and lower operating costs
- Minimum slime build-up can help lower cleaning costs

#### Precision FLOWTITE

with elastomeric REKA gaskets

- Tight, efficient joints designed for coupling to eliminate infiltration and ex-filtration
- Ease of joining, reducing installation time
- Accommodates small changes in line direction without fittings or differential settlement

#### Flexible manufacturing

- Custom diameters can be process manufactured to provide maximum flow volumes with ease of installation for rehabilitation lining projects

#### High technology pipe design

- Lower wave celerity than other piping materials can mean less cost when designing for surge and water hammer pressures

#### High technology pipe manufacturing system

- High and consistent product quality worldwide which produces pipe ensures a reliable product

that complies to stringent performance standards (AWWA, ASTM, DIN, EN, etc.)

- Quick and easy installation with construction site equipment due to light weight
- Fast installation with a reduced number of couplings due to pipe lengths up to 18 m
- simple and inexpensive tightness tests
- long usage with consistently high flow rates
- minimal effort for repairs and maintenance
- excellent corrosion resistance
- reinforced inner surface with a high resistance against abrasion

Due to these factors, projects made with FLOWTITE pipe systems are very economical and long-lasting with low maintenance efforts over the years.

## 3 Certificates and Approvals

FLOWTITE pipe systems have been tested and approved for the conveyance of raw water meeting many of the world's leading authorities' and testing institutes' criteria, including:

- NSF (Standard No. 61) – United States
- DVGW – Germany
- Lyonnaise des Eaux – France
- Sanitary and Hygienic Conclusion – Russia
- Hygienic Conclusion of Sanitary and Epidemiological Expertise about the Product Security – Kazakhstan
- Oficina Técnica De Estudios Y Controles – Spain
- Państwowy Zakład Higieny (National Institute of Hygiene) – Poland
- ÖVGW – Austria
- NBN.S. 29001 – Belgium
- KIWA – Netherlands

FLOWTITE pipe systems fulfil the product standards AWWA, ASTM, DIN, ISO and EN.

Other local approvals are also available, dependent on country specific requirements.

Amiantit is participating in the development of all these standards with representatives of all the worldwide organisations, thereby ensuring performance requirements will result in reliable products.

Local approvals and certifications are attached at the inner package of this brochure.

# 4 Quality Characteristics

01

02

03

04

05

06

07

08

## 4.1 Raw Materials

Raw materials are delivered with vendor certification demonstrating their compliance with Flowtite quality requirements. In addition, all raw materials are sample tested prior to their use. These tests ensure that the pipe materials comply with the specifications as stated. Raw materials should be, according to Flowtite quality requirements, pre-qualified in such a way that their suitability to be used in the process and in the final product is demonstrated.

### Raw Materials used in pipe production are:

- Glass
- Resin
- Catalyst
- Sand
- Additives

Only FLOWTITE approved raw materials can be used for the production of the FLOWTITE pipe.

### Glass

Glass is specified by tex which is = weight in grams/1000 meters length  
Hoop roving: Continuous roving used in different tex for the production of the FLOWTITE pipe  
Chop roving cut directly on the machine to provide strength in different directions.

### Resin

Only qualified resin for the winding process. Usually it is delivered in drums or bulk. The resin is prepared in day tanks at the winder. Normal application temperature is 25°C. Resin is delivered from the producer and may be diluted before use on the winder with styrene to reach the required and acceptable viscosity, as defined by FLOWTITE Technology.

### Catalyst

The right amount of catalyst is added to the resin for curing the mix right before application on the mandrel. Only approved catalysts are used in the manufacturing process of the FLOWTITE pipes.

### Sand

Sand is added to the core of the pipe and the inner layer of couplings. High silica sand must be within the FLOWTITE specifications for approved raw material.

### Additives

Additives are used as accelerator for the resin and are mixed with it in the day tanks. The additives are available in different concentration and may be diluted by the producers in mineral spirit to reach the required concentration needed for the production of the FLOWTITE pipes.

## 4.2 Physical Properties

The manufactured pipe's hoop and axial load capacities are verified on a routine basis. In addition, pipe stiffness and deflection tests are carried out in accordance with our internal Flowtite quality regulations.

## 4.3 Finished Pipe Properties

100% of all finished pipes for raw water are checked for the following:

- Visual inspection
- Barcol hardness
- Wall thickness
- Section length
- Diameter
- Hydrostatic leak tightness test to twice rated pressure (PN 6 and above)  
**! Note:** Pressure and diameters are limited by the hydrotest capacity

## 4.4 Other Quality Characteristics

More detailed information about many other quality characteristics such as:

- Hydrostatic Design Basis – HDB
- Long-term Ring Bending
- Hydro-testing
- Surge and Water Hammer
- Load Capacity Values
- Hoop Tensile Load Capacity
- Axial Tensile Load Capacity
- Flow Velocity
- UV Resistance
- Poisson's Ratio
- Flow Coefficients
- Abrasion Resistance

can be found in our brochure "Technical Characteristics" of FLOWTITE pipes.

## 5 Product Range

FLOWTITE pipe systems are supplied in nominal diameters ranging from DN 80 up to DN 4000 mm. The nominal diameter is considered as the inside diameter. The **standard** diameter range in mm is defined as below:

100 · 150 · 200 · 250 · 300 · 350 · 400 · 450 · 500 · 600 · 700 · 800 · 900 · 1000
1100 · 1200 · 1400 · 1600 · 1800 · 2000 · 2200 · 2400 · 2600 · 2800 · 3000

The locally manufactured standard diameter range varies according to manufacturing facilities. For detailed information, please do not hesitate to contact your on-site contact. Larger diameters than DN 3000 up to 4000 mm and other diameters are available on request.

### 5.1 Stiffness Classes

FLOWTITE pipe systems show the following specific initial stiffness ( $EI/D^3$ ) expressed in  $N/m^2$  and the FLOWTITE standard is defined as follows:

Stiffness Class SN	Stiffness ( $N/m^2$ )
2500	2500
5000	5000
10000	10000

**Table 5-1 Stiffness Class**

Other stiffness classes are available on request. We also supply custom-designed pipe systems with a stiffness tailored to the needs of the project.

### 5.2 Pressure

Our FLOWTITE pipe systems for raw water applications are supplied in the standard pressure classes as listed below:

Pressure Class PN	Pressure Rating Bar	Upper diameter limit
1	1	3000
6	6	3000
10	10	3000
16	16	3000
20	20	3000
25	25	2400
32	32	1800

**Table 5-2 Pressure Class**

Custom-designed pipes with pressure tailored to the needs of the project are also available.

### 5.3 Length

Our FLOWTITE Pipes for raw water are available in standard length of 6, 12 and 14 m. Other tailor-made lengths are available on request. Diameters smaller than DN 300 are available only in 6m standard lengths.

### 5.4 Hydro-Testing

Maximum Factory Test Pressure for Pipes PN 6 and above is 2.0 x PN (Pressure Class). Maximum Field Test Pressure 1.5 x PN (Pressure Class). Pressure and diameter upper limit are functions of the hydrotest capacity in the plants.

### 5.5 Standard Pipe and Coupling Data Sheet

Our Flowtite pipe systems for raw water applications are supplied in the standard diameter range, pressure and stiffness classes as listed below. Other diameters and pressure classes are available on request.

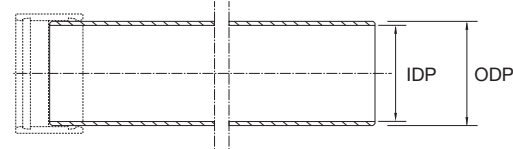

**Pipe FPP**

"B2" - OD Series	SN	10000			
	PN	10/16			
	DN	ODP	IDP	kg/m*	
		mm	mm	mm	
		100	116.4	109.2	2.0
		150	168.4	158.8	4.2
		200	220.9	208.9	7.3
		250	272.5	258.3	11.0
		300	325.1	308.5	15.4

\* Approx. Weights

**Table 5-3 Small Diameters - Pipe Thickness & Weight**

SN = Pipe stiffness, PN = Nominal Pressure, ODP = Outside diameter of pipe, IDP = Inside diameter of pipe

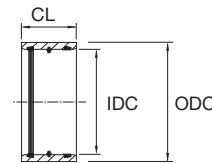

**Double Bell Coupling FPC**

"B2" - OD Series	SN	10000				
	PN	10/16				
	DN	IDC	ODC	CL	kg/pc*	
		mm	mm	mm		
		100	116.5	138.9	150	1.3
		150	168.5	190.9	150	2.1
		200	222.0	256.4	175	4.2
		250	273.6	308.0	175	5.1
		300	326.0	360.4	175	6.0

\* Approx. Weights

**Table 5-4 Small Diameters - Coupling Thickness & Weight**

SN = Pipe stiffness, PN = Nominal Pressure, ODC = outside diameter of coupling, IDC = Inside diameter of coupling, CL = Coupling length

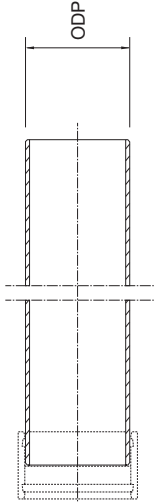

**Pipe FPP**

DN	PN	SN	2500					5000					10000								
			1	6	10	16	20	1	6	10	16	20	25	1	6	10	16	20	25	32	
mm	ODP	mm	kg/m*	kg/m*	kg/m*	kg/m*	kg/m*	kg/m*	kg/m*	kg/m*	kg/m*	kg/m*	kg/m*	kg/m*	kg/m*	kg/m*	kg/m*	kg/m*	kg/m*	kg/m*	kg/m*
300			8.1	8.1	7.9	7.4	7.3	10.3	10.3	10.2	9.4	9.2	9.1	12.6	12.6	12.6	12.1	11.7	11.4	11.2	
350			11.0	11.0	10.5	9.9	9.8	14.2	14.2	13.7	12.5	12.2	12.1	17.2	17.2	17.2	16.2	15.5	15.2	14.8	
400			14.4	14.4	13.4	12.5	12.4	18.4	18.4	17.5	16.0	15.7	15.3	22.3	22.3	22.3	20.7	20.0	19.4	18.9	
450			18.3	18.3	16.7	15.7	15.4	23.4	23.4	21.7	19.8	19.5	19.0	28.1	28.1	28.1	25.2	25.0	24.2	23.4	
500			22.8	22.8	20.4	19.1	18.7	29.1	29.1	26.7	24.5	23.7	23.2	34.8	34.8	34.8	31.6	30.5	29.5	28.6	
600			31.3	31.3	27.4	25.6	25.0	39.2	39.2	35.9	32.8	31.8	30.9	47.8	47.8	47.8	42.9	41.0	39.6	38.3	
700			42.2	42.2	37.0	34.3	33.5	53.0	53.0	48.6	44.2	42.7	41.6	65.5	65.5	65.5	57.9	55.3	53.3	51.6	
800			54.8	54.8	48.1	44.3	43.3	68.6	68.6	62.9	57.2	55.2	53.8	85.1	85.1	85.1	74.9	71.6	69.0	66.8	
900			69.2	69.2	60.6	55.6	54.2	86.5	86.5	80.3	71.9	69.4	67.5	107.1	107.1	107.1	94.6	90.1	86.8	83.9	
1000			85.3	85.3	74.5	68.1	66.4	106.0	106.0	98.8	88.3	85.1	82.8	132.4	132.4	132.4	116.2	110.6	106.6	103.1	
1100			103.1	103.1	89.6	82.0	79.9	128.1	128.1	119.1	106.2	102.5	99.7	160.3	160.3	160.3	140.2	133.4	128.4	124.2	
1200			121.9	121.9	106.1	97.1	94.5	151.5	151.5	141.5	125.8	121.4	118.0	190.0	190.0	190.0	166.3	158.2	152.3	147.2	
1300			143.1	143.1	124.1	113.4	110.4	178.7	178.7	165.6	147.2	142.0	138.0	222.8	222.8	222.8	194.4	185.2	178.1	172.2	
1400			165.3	165.3	143.7	131.1	127.6	206.5	206.5	191.3	170.4	164.1	159.5	257.8	257.8	257.8	225.4	214.5	206.1	199.1	
1500			188.5	188.5	164.1	149.9	156.1	237.4	237.4	219.3	195.0	201.9	195.7	294.8	294.8	294.8	258.3	244.7	235.1	228.4	
1600			214.9	214.9	186.8	170.1	177.1	269.2	269.2	249.5	221.4	229.2	222.2	335.8	335.8	335.8	293.3	288.4	277.8	271.8	
1700			244.3	244.3	210.4	191.5	199.4	303.8	303.8	281.0	249.6	258.2	250.2	378.0	378.0	378.0	330.6	339.2	325.1	310.9	
1800			273.3	273.3	235.4	214.3	223.0	340.4	340.4	314.6	279.1	288.9	279.9	423.7	423.7	423.7	370.5	379.8	363.9	340.3	
1900			303.4	303.4	261.4	238.2	248.0	378.4	378.4	350.2	310.4	321.4	312.2	471.8	471.8	471.8	411.8	422.6	404.8	380.8	
2000			335.9	335.9	289.7	263.3	274.2	418.3	418.3	387.7	343.7	355.6	344.5	521.3	521.3	521.3	455.9	467.5	449.1	426.1	
2100			370.0	370.0	319.0	290.0	301.9	461.1	461.1	426.7	378.3	391.5	374.2	574.7	574.7	574.7	502.1	515.1	493.8	472.6	
2200			405.5	405.5	349.6	317.7	330.9	505.8	505.8	468.0	414.8	429.2	402.4	630.3	630.3	630.3	550.6	564.5	536.5	515.5	
2300			442.8	442.8	382.0	346.7	361.0	551.5	551.5	511.9	452.8	468.6	432.3	687.8	687.8	687.8	601.8	616.6	578.7	558.7	
2400			481.8	481.8	414.8	377.1	392.7	600.1	600.1	556.7	492.7	509.5	462.6	747.9	747.9	747.9	654.7	670.7	622.3	602.3	
2500			521.1	521.1	450.1	408.6	419.3	651.8	651.8	603.7	533.9	552.6	462.6	812.3	812.3	812.3	710.1	728.8	688.8	668.8	
2600			564.4	564.4	486.4	441.6	445.1	704.3	704.3	652.0	577.4	590.8	528.8	878.5	878.5	878.5	766.9	786.1	746.1	726.1	
2700			608.3	608.3	523.9	475.4	471.6	758.0	758.0	702.9	622.2	628.8	562.8	946.5	946.5	946.5	827.3	846.2	806.2	786.2	
2800			652.5	652.5	563.4	511.1	500.2	815.4	815.4	756.0	668.7	669.0	602.6	1017.8	1017.8	1017.8	888.5	902.6	862.6	842.6	
2900			699.9	699.9	603.7	546.5	528.7	875.0	875.0	810.0	716.3	709.6	642.6	1089.6	1089.6	1089.6	953.3	969.9	929.9	909.9	
3000			749.8	749.8	646.0	585.6	558.2	935.3	935.3	866.1	766.5	751.7	686.6	1166.8	1166.8	1166.8	1019.7	1039.7	999.7	979.7	

\* Approx. Weights

**Table 5-5 Large Diameters – Pipe data**

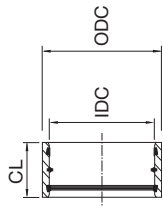

**Double Bell Coupling FPC**

Coupling DN	Length CL mm	IDC mm	1 / 6		10		16		20		25		32	
			ODC mm	kg/pc*	ODC mm	kg/pc*	ODC mm	kg/pc*	ODC mm	kg/pc*	ODC mm	kg/pc*	ODC mm	kg/pc*
300	270	326.0	367.8	10.9	368.6	11.1	369.8	11.4	370.4	11.7	371.0	11.7	377.8	16.4
350	270	377.9	419.5	12.4	420.7	12.8	422.1	13.3	422.1	13.3	423.3	13.6	430.5	19.1
400	270	428.8	470.4	14.0	471.6	14.5	474.2	15.6	473.4	15.2	474.4	15.6	481.6	18.2
450	270	479.7	520.9	15.6	522.5	16.3	524.5	17.1	524.7	17.1	525.9	17.5	533.1	20.6
500	270	531.6	572.6	17.2	574.2	17.9	576.0	18.7	577.4	19.3	578.8	20.0	584.8	22.7
600	330	618.5	666.1	28.6	667.7	29.6	669.9	31.0	672.3	32.5	675.1	34.3	682.3	39.0
700	330	720.5	767.7	32.8	770.1	34.5	774.5	37.8	775.1	37.9	777.9	40.1	787.7	47.4
800	330	822.5	869.5	37.1	873.7	40.6	878.9	44.9	879.5	45.1	883.5	48.6	898.9	61.6
900	330	924.5	972.5	42.5	977.1	46.8	980.3	49.1	982.7	51.1	988.5	56.6	1005.3	106.2
1000	330	1026.5	1075.5	48.1	1080.3	53.1	1083.9	56.0	1086.9	58.8	1099.5	72.0	1116.1	131.4
1100	330	1128.5	1178.1	53.5	1183.5	59.5	1187.5	63.3	1192.3	68.4	1208.1	86.6	1224.3	142.7
1200	330	1230.5	1280.7	58.9	1286.5	65.9	1291.1	70.9	1300.1	81.7	1314.9	100.3	1331.1	166.9
1300	330	1332.5	1380.8	64.4	1388.8	72.4	1394.2	78.6	1406.3	94.0	1420.9	113.6	1436.7	188.3
1400	330	1434.5	1485.7	69.9	1491.9	78.7	1499.5	88.6	1511.9	106.2	1526.1	126.7	1541.5	210.1
1500	330	1536.5	1587.6	75.4	1594.2	85.4	1604.4	100.1	1616.4	119.2	1630.4	141.2	1645.4	165.1
1600	330	1638.5	1690.7	81.2	1697.5	92.3	1709.9	111.4	1721.0	131.2	1734.6	154.1	1749.2	178.8
1700	330	1740.5	1790.1	86.9	1797.1	99.3	1809.5	122.3	1825.0	142.8	1838.6	167.0	1852.8	192.4
1800	330	1842.5	1895.5	92.6	1902.9	106.2	1918.3	133.1	1929.0	154.6	1942.2	179.4	1956.2	205.9
1900	330	1944.5	1995.3	98.5	2002.3	115.1	2020.7	144.2	2032.6	166.2	2045.4	191.4	-	-
2000	330	2046.5	2100.3	104.4	2110.1	124.4	2125.9	154.8	2136.2	178.0	2148.4	203.3	-	-
2100	330	2148.5	2199.9	110.4	2209.9	133.8	2228.8	167.0	2239.4	189.4	2251.2	215.1	-	-
2200	330	2250.5	2305.1	116.4	2316.9	142.7	2332.2	177.8	2342.8	201.2	2354.0	226.8	-	-
2300	330	2352.5	2404.5	122.6	2415.5	151.8	2435.2	188.3	2445.8	212.6	2456.8	238.7	-	-
2400	330	2454.5	2509.9	128.8	2523.3	161.1	2538.4	199.2	2548.8	224.1	2559.4	250.3	-	-
2500	330	2556.5	2628.0	187.7	2646.4	224.7	2661.8	261.4	2671.6	285.5	-	-	-	-
2600	360	2658.5	2733.5	208.8	2742.6	237.9	2753.8	267.2	2767.4	305.3	-	-	-	-
2700	360	2760.5	2730.4	218.4	2845.2	248.6	2857.4	282.3	2871.6	323.6	-	-	-	-
2800	360	2862.5	2938.7	228.2	2947.8	259.5	2961.2	298.1	2976.0	342.7	-	-	-	-
2900	360	2964.5	3035.7	238.1	3050.4	270.6	3065.2	314.8	3080.2	362.0	-	-	-	-
3000	360	3066.5	3143.9	248.2	3153.0	281.7	3169.0	331.6	3184.6	382.2	-	-	-	-

\* Approx. Weights

**Table 5-6 Large Diameters – Double Bell Coupling data**

# 6 Pipe Joining

- 01
- 02
- 03
- 04
- 05
- 06
- 07
- 08

## 6.1 Double Bell Coupling (FPC)

FLOWTITE pipe sections are typically joined using FLOWTITE Pressure GRP couplings (FPC). Pipe and couplings may be supplied separately, or the pipe may be supplied with a coupling installed on one end. The FLOWTITE coupling utilises an elastomeric gasket (REKA system) for sealing. The gasket sits in a precision-machined groove in each end of the coupling and seats and seals against a spigot surface. The REKA gasket system has been proven in use for more than 75 years.

**Note:** Detailed installation instructions can be found in our separate publications for pipe installation.

The pipes must be joined in a straight alignment, but not all the way to the home line, and thereafter deflected angularly as required.

**Note:** The specified angular deflection is the total deflection including deflection due to settlement. Use 50-70% of the value in initial installation.

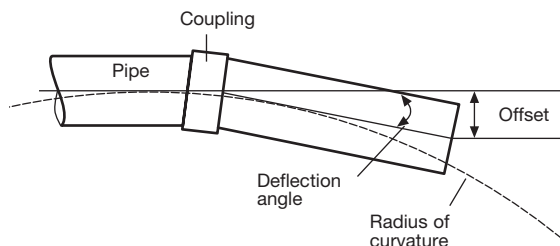

### Joint Angular Deflection

The joint is extensively tested and qualified in accordance with ASTM D4161, ISO DIS8639 and EN 1119. Maximum angular deflection (turn) at each coupling joint, measured as the change in adjacent pipe centre lines, must not exceed the amounts given in table below.

Nom Pipe Diameter (mm)	Pressure (PN) in bars			
	Up to 16	20	25	32
		Max. Angle of Deflection (deg)		
DN ≤ 500	3.0	2.5	2.0	1.5
500 < DN ≤ 800	2.0	1.5	1.3	1.0
900 < DN ≤ 1800	1.0	0.8	0.5	0.5
DN > 1800	0.5	NA	NA	NA

Table 6-1 Angular Deflection at Double Coupling Joint

Angle of Deflection (deg)	Maximum Offset (mm) Pipe length			Radius of Curvature (m) Pipe length		
	3 m	6 m	12 m	3 m	6 m	12 m
3.0	157	314	628	57	115	229
2.5	136	261	523	69	137	275
2.0	105	209	419	86	172	344
1.5	78	157	313	114	228	456
1.3	65	120	240	132	265	529
1.0	52	105	209	172	344	688
0.8	39	78	156	215	430	860
0.5	26	52	104	344	688	1376

Table 6-2 Offset and Radius of Curvature



## 6.2 Locked Joints

The FLOWTITE locked joint is a double bell with rubber gaskets and locking rods to transfer axial thrust from one pipe section to another. On each side, the coupling bell has a standard rubber gasket and a rod-groove system, through which the load is transferred via compressive and shear action. The pipe spigot for locked joints has a matching groove.

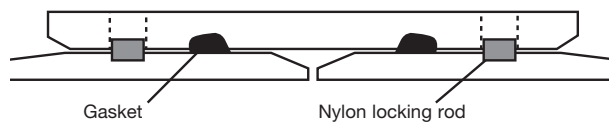

**Figure 6-1 Locked Joint**

The joint is assembled by using a similar procedure as the standard FLOWTITE coupling, except that there is no centre register.

## 6.3 Other Joining Systems

### GRP Flanges

The standard bolt pattern to which our flanges are manufactured is in accordance with ISO2084. Other bolting dimension systems such as AWWA, ANSI, DIN and JIS can also be supplied. Available are flange connections with fibreglass adhesives, as well as zinc steel loose-type flanges. Fibreglass tight flanges and loose-type flanges made of fibreglass can be delivered to order. Loose and fixed flanges are available for all pressure classes.

Contact moulded Flanged joints:

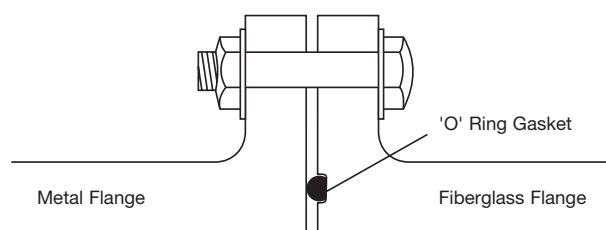

**Figure 6-2 Flanged Joint**

Fixed Flange joints:

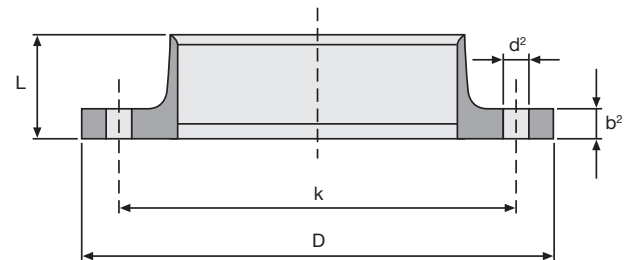

**Figure 6-3 Fixed Flanged Joint**

Loose Ring Flanges:

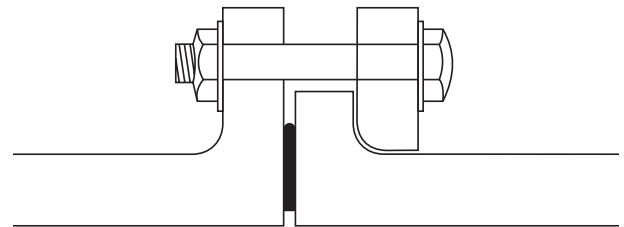
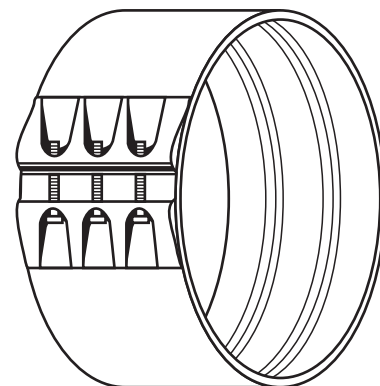

**Figure 6-4 Loose Ring with Flat Gasket  
incl. Steel Support**

### Mechanical Steel Couplings

When connecting FLOWTITE pipe to other materials with different outside diameters, flexible steel couplings are one of the preferred joining methods. These couplings consist of a steel mantle with an interior rubber sealing sleeve. They may also be used to join FLOWTITE pipe sections together, for example in a repair or for closure. Three grades are commonly available:

- Coated steel mantle
- Stainless steel mantle
- Hot dip galvanized steel mantle



**Figure 6-5 Flexible Steel Coupling**

Mechanical couplings have been used to join pipes of different materials and diameters, and to adapt to flange outlets. FLOWTITE Technology has found a wide manufacturing variance in these couplings, including bolt size, number of bolts and gasket design which makes standardized recommendations impossible. If a mechanical joint is used to join FLOWTITE to another pipe material then a dual independent bolting system allows for the independent tightening of the FLOWTITE side which typically requires less torque than recommended by the coupling manufacturer.

Consequently, we cannot recommend the general use of mechanical couplings with FLOWTITE pipe. If the installer intends to use a specific design (brand and model) of mechanical coupling, he is advised to consult with the local FLOWTITE pipe supplier prior to its purchase. The pipe supplier can then advise under what specific conditions, if any, this design might be suitable for use with FLOWTITE.

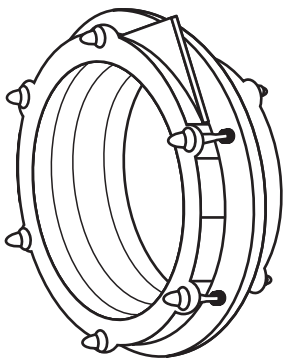
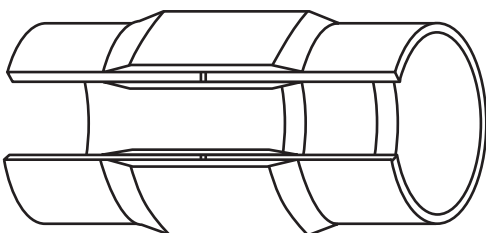

**Figure 6-6 Dual Bolt Mechanical Coupling**

### **Laminated Joints (Butt strap)**

Laminated Joints are typically where the transmission of axial forces from internal pressure is required, or as a repair method. The length and thickness of the lay-up depends on diameter and pressure.

Detailed information about the local availability of joints and joining systems can be requested from your local supplier, or is attached to this brochure.



**Figure 6-7 Laminated Joint**

## 7 Accessories

FLOWTITE Technology has created a standardised line of GRP fittings that are moulded or fabricated using the same materials that are used to produce FLOWTITE pipe. One of the benefits of FLOWTITE pipe is the ability to fabricate a wide assortment of fittings, standard as well as non-standard.

The standard delivery of our fittings include the coupling pre-mounted at one/one both ends. Additionally we are able to supply complete spools with pre-installed flange connections.

**Segmented Bends:**  
See section 7.1 →

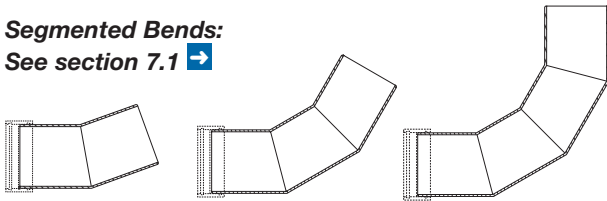

**Segmented Reducers – Concentric – :**  
See section 7.2 →

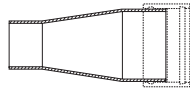

**Segmented Tees – Equal and Reduced – :**  
See section 7.3 →

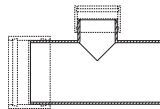

**Moulded Bends:**  
See section 7.4 →

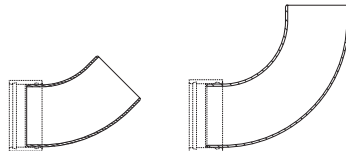

**Moulded Reducers – Concentric – :**  
See section 7.5 →

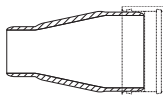

**Moulded Tees – Equal and Reduced – :**  
See section 7.6 →

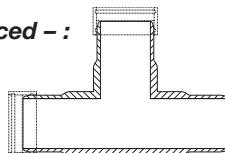

**Wall Couplings:**  
See section 7.7 →

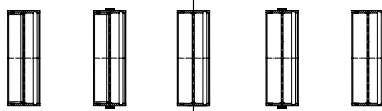

The manufacturing of our accessories follows internationally well accepted ISO standards.

**By ordering fittings in dimensions above DN 1600 it has to be checked if the requested fittings can be transported or if it has to be delivered in parts and assembled on site!**

**Fix Flanges – Type A:**  
See section 7.8 →

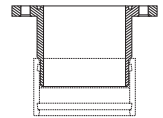

**Fix Flanges – Type B: (laminated on pipe ends)**  
See section 7.9 →



**Blind Flanges:**  
See section 7.10 →



**Loose Flanges and Collars:**  
See section 7.11 →



**Wall Connection Pieces:**  
See section 7.12 – 7.14 →



**Short Section Pipes:**  
See section 7.15 →

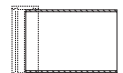

**Valve Chambers:**  
See section 7.16 →

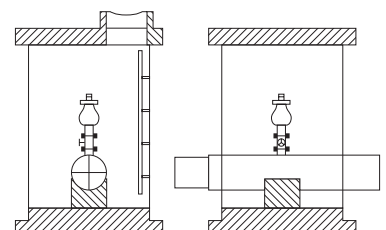

# 7.1 Segmented Bends

- 01
- 02
- 03
- 04
- 05
- 06
- 07
- 08

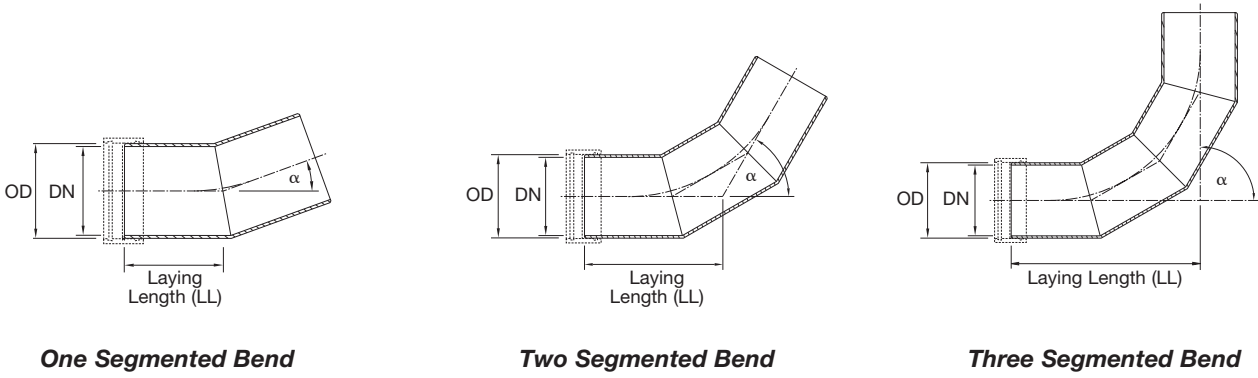

		Angle $\alpha$						
"B2" OD Series		11.25°	15°	22.5°	30°	45°	60°	90°
DN	OD	No. of Mitres with Laying Length (LL) [mm]						
mm	mm	1	1	1	1	2	2	3
100	116	250	250	250	250	250	300	350
150	168	250	250	250	250	300	300	400
200	220	250	250	250	300	350	400	500
250	272	300	300	300	300	400	450	600
300	324	400	350	400	400	500	550	750
350	376	400	400	400	450	550	600	800
400	427	450	450	450	450	600	650	900
450	478	450	450	500	500	600	700	1000
500	530	450	450	500	500	650	750	1050

**Table 7-1-1 Small Diameters – Laying Length LL in mm – Stiffness and Pressure Classes acc. to Table 5-1 and 5-2**

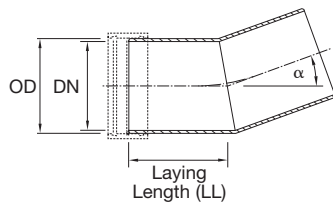
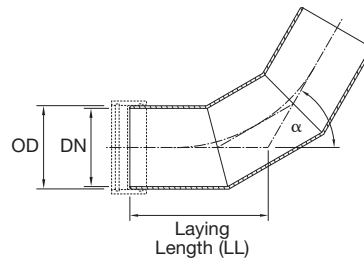
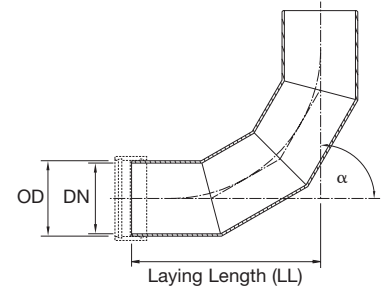
**One Segmented Bend****Two Segmented Bend****Three Segmented Bend**

„B1“ OD Series*		Angle $\alpha$						
		11.25°	15°	22.5°	30°	45°	60°	90°
DN	OD	No. of Mitres with Laying Length (LL) [mm]						
mm	mm	1	1	1	1	2	2	3
600	617	400	400	400	450	600	700	1100
700	719	400	400	450	450	650	800	1200
800	821	450	450	450	500	700	850	1350
900	923	450	450	500	550	800	950	1500
1000	1025	450	500	500	550	850	1000	1650
1100	1217	500	500	550	600	900	1100	1800
1200	1229	500	550	600	600	950	1200	1950
1300	1331	600	600	650	700	1050	1300	2100
1400	1433	600	600	650	700	1100	1350	2250
1500	1535	650	650	700	750	1200	1450	2400
1600	1637	650	700	750	800	1250	1550	2550
1700	1739	650	700	750	800	1300	1600	2700
1800	1841	700	750	800	850	1350	1700	2850
1900	1943	700	750	800	850	1400	1750	2950
2000	2045	700	750	800	900	1450	1800	3100
2100	2147	700	750	800	900	1500	1850	3200
2200	2249	700	750	800	900	1550	1950	3350
2300	2351	700	750	800	950	1550	2000	3450
2400	2453	700	750	800	1000	1550	2100	3600
2500	2555	700	750	800	1000	1600	2200	3750
2600	2657	700	800	900	1000	1700	2200	3800
2700	2759	800	800	900	1000	1800	2200	4000
2800	2861	800	800	900	1000	1800	2300	4100
2900	2963	800	800	900	1000	1900	2400	4200
3000	3065	800	800	900	1100	1900	2400	4300

**Table 7-1-2 Large Diameters – Laying Length LL in mm – Stiffness and Pressure Classes acc. to Table 5-1 and 5-2**

## 7.2 Segmented Reducers – Concentric –

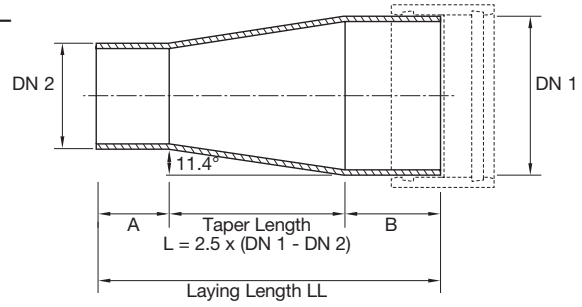

DN1	DN2	Taper Length L [mm]	Pipe Length A=B [mm],	Laying Length LL [mm]
150	100	125	300	725
200	100	250	300	850
200	150	125	300	725
250	150	250	300	850
250	200	125	300	725
300	200	250	400	1050
300	250	125	400	925
350	250	250	400	1050
350	300	125	400	925
400	300	250	400	1050
400	350	125	400	925
450	350	250	400	1050
450	400	125	400	925
500	400	250	400	1050
500	450	125	400	925
600	400	500	400	1300
600	450	375	400	1175
600	500	250	400	1050
700	500	500	400	1300
700	600	250	400	1050
800	600	500	400	1300
800	700	250	400	1050
900	700	500	400	1300
900	800	250	400	1050
1000	800	500	400	1300
1000	900	250	400	1050
1100	900	500	500	1500
1100	1000	250	500	1250
1200	800	1000	500	2000
1200	1000	500	500	1500
1200	1100	250	500	1250
1300	1100	500	500	1500
1300	1200	250	500	1250
1400	1200	500	500	1500
1400	1300	250	500	1250

DN1	DN2	Taper Length L [mm]	Pipe Length A=B [mm],	Laying Length LL [mm]
1500	1300	500	600	1700
1500	1400	250	600	1450
1600	1200	1000	600	2200
1600	1400	500	600	1700
1600	1500	250	600	1450
1700	1500	500	600	1700
1700	1600	250	600	1450
1800	1600	500	600	1700
1800	1700	250	600	1450
1900	1700	500	600	1700
1900	1800	250	600	1450
2000	1800	500	600	1700
2000	1900	250	600	1450
2100	1900	500	600	1700
2100	2000	250	600	1450
2200	2000	500	600	1700
2200	2100	250	600	1450
2300	2100	500	600	1700
2300	2200	250	600	1450
2400	2200	500	600	1700
2400	2300	250	600	1450
2500	2300	500	600	1700
2500	2400	250	600	1450
2600	2200	1000	600	2200
2600	2400	500	600	1700
2700	2500	500	600	1700
2700	2600	250	600	1450
2800	2400	1000	600	2200
2800	2600	500	600	1700
2900	2700	500	600	1700
2900	2800	250	600	1450
3000	2600	1000	600	2200
3000	2800	500	600	1700

**Table 7-2 Concentric Reducers – Stiffness and Pressure Classes acc. to Table 5-1 and 5-2**

- 01
- 02
- 03
- 04
- 05
- 06
- 07
- 08

## 7.3 Segmented Tees – Equal and Reduced –

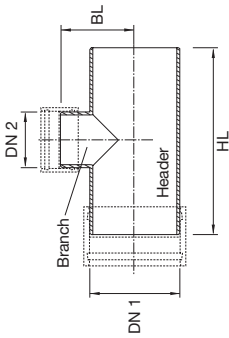

**Segmented Tees**  
**Pressure Class PN 1**  
**DN 2 = 100 – 1100 mm**

DN 2 \ DN 1	100		150		200		300		350		400		450		500		600		700		800		900		1000		1100		
	HL	BL	HL	BL	HL	BL	HL	BL	HL	BL	HL	BL	HL	BL	HL	BL	HL	BL	HL	BL	HL	BL	HL	BL	HL	BL	HL	BL	
300	720	380	780	380	820	400	920	460	-	-	-	-	-	-	-	-	-	-	-	-	-	-	-	-	-	-	-	-	
350	720	400	780	400	820	420	920	500	980	500	-	-	-	-	-	-	-	-	-	-	-	-	-	-	-	-	-	-	-
400	720	440	780	440	820	440	920	520	980	520	1020	520	-	-	-	-	-	-	-	-	-	-	-	-	-	-	-	-	-
450	720	460	780	460	840	480	940	540	980	540	1040	540	1100	560	-	-	-	-	-	-	-	-	-	-	-	-	-	-	-
500	720	480	780	480	840	500	940	560	1000	580	1040	580	1100	580	1160	580	-	-	-	-	-	-	-	-	-	-	-	-	-
600	780	520	840	520	900	540	1000	620	1060	620	1100	620	1180	640	1240	640	1360	680	-	-	-	-	-	-	-	-	-	-	-
700	800	580	860	580	900	600	1020	660	1060	660	1120	680	1180	680	1240	680	1360	740	1500	760	-	-	-	-	-	-	-	-	-
800	800	620	860	640	900	640	1020	720	1080	720	1120	720	1180	740	1240	740	1380	800	1640	1520	840	-	-	-	-	-	-	-	-
900	800	680	860	680	920	700	1020	780	1080	780	1140	780	1200	780	1260	800	1380	840	1660	1520	880	1780	900	-	-	-	-	-	-
1000	850	750	900	750	950	750	1050	850	1100	850	1150	850	1200	850	1300	850	1400	900	1700	1550	950	1800	950	1950	1000	-	-	-	-
1100	850	800	900	800	950	800	1050	900	1100	900	1150	900	1200	900	1300	900	1400	950	1700	1550	1000	1800	1000	1950	1050	2500	2500	2500	1250
1200	850	850	900	850	950	900	1050	950	1100	950	1150	950	1250	950	1300	950	1400	1000	1700	1550	1050	1850	1100	2000	1100	2500	2500	2500	1300
1300	850	900	950	900	1000	950	1100	1000	1150	1000	1200	1000	1250	1000	1300	1000	1450	1050	1700	1550	1100	1850	1150	2000	1150	2500	2500	2500	1400
1400	900	950	950	950	1000	1000	1100	1050	1150	1050	1200	1050	1250	1050	1350	1050	1450	1100	1700	1550	1150	1850	1200	2000	1200	2500	2500	2500	1450
1500	900	1000	950	1000	1000	1050	1150	1100	1200	1100	1250	1100	1300	1100	1350	1100	1450	1200	1700	1600	1200	1850	1250	2000	1250	2500	2500	2500	1500
1600	950	1050	1000	1050	1050	1100	1150	1150	1200	1150	1250	1150	1300	1150	1350	1150	1450	1250	1700	1600	1250	1850	1300	2000	1300	2500	2500	2500	1550
1700	950	1100	1000	1050	1050	1150	1150	1200	1200	1200	1250	1200	1300	1200	1350	1200	1400	1300	1750	1600	1300	1850	1350	2000	1350	2500	2500	2500	1600
1800	1000	1200	1050	1200	1100	1200	1200	1250	1250	1250	1300	1250	1350	1300	1400	1300	1450	1350	1750	1600	1350	1850	1400	2050	1400	2500	2500	2500	1650
1900	1000	1250	1050	1250	1100	1250	1200	1300	1250	1300	1300	1300	1350	1350	1400	1350	1500	1400	1750	1600	1400	1900	1450	2050	1450	2500	2500	2500	1700
2000	1000	1300	1100	1300	1100	1300	1300	1400	1300	1400	1400	1400	1400	1400	1500	1400	1600	1500	1800	1700	1500	1900	1500	2100	1500	2500	2500	2500	1800
2100	1100	1400	1100	1400	1200	1400	1300	1400	1300	1400	1400	1400	1400	1500	1500	1500	1600	1600	1800	1700	1500	1900	1600	2100	1600	2500	2500	2500	1800
2200	1100	1400	1100	1400	1200	1400	1300	1500	1300	1500	1400	1500	1500	1500	1500	1500	1600	1600	1800	1700	1600	1900	1600	2100	1600	2500	2500	2500	1900
2300	1100	1500	1200	1500	1200	1500	1300	1600	1400	1600	1400	1600	1500	1600	1600	1600	1700	1700	1800	1700	1600	1900	1700	2100	1700	2500	2500	2500	1900
2400	1100	1500	1200	1500	1200	1500	1300	1600	1400	1600	1400	1600	1500	1600	1600	1600	1700	1700	1800	1700	1600	1900	1700	2100	1700	2500	2500	2500	1900
2500	1100	1600	1200	1600	1200	1600	1400	1700	1400	1700	1500	1700	1500	1700	1600	1700	1700	1800	1700	1600	1900	1800	1800	2100	1800	2500	2500	2500	2000
2600	1200	1600	1200	1600	1300	1600	1400	1700	1400	1700	1500	1700	1600	1700	1600	1700	1700	1800	1700	1600	1900	1800	1800	2100	1800	2500	2500	2500	2100
2700	1200	1700	1300	1700	1300	1700	1400	1800	1500	1800	1500	1800	1600	1800	1600	1800	1800	1900	1800	1700	1900	1900	1900	2200	1900	2500	2500	2500	2100
2800	1200	1700	1300	1700	1300	1700	1400	1800	1500	1800	1500	1800	1600	1800	1700	1800	1800	1900	1800	1700	1900	1900	1900	2200	1900	2500	2500	2500	2200
2900	1300	1800	1300	1800	1400	1800	1500	1900	1500	1900	1600	1900	1600	1900	1700	1900	1900	2000	1900	1800	2000	2000	2000	2200	2000	2500	2500	2500	2200
3000	1300	1800	1300	1800	1400	1900	1500	1900	1500	1900	1600	1900	1600	1900	1700	1900	1900	2000	2000	1900	2000	2000	2000	2200	2000	2500	2500	2500	2300

**Table 7-3-1 Header- and Branch Lengths Segmented Tee Pipe Series in mm – PN 1 – Stiffness Classes acc. to Table 5-1**

**Segmented Tees  
Pressure Class PN 1  
DN 2 = 1200 – 2600 mm**

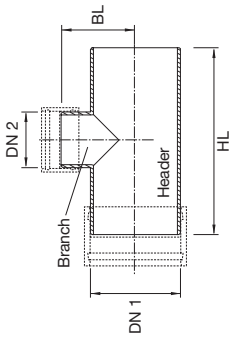

DN 2 DN 1	1200		1300		1400		1500		1600		1700		1800		1900		2000		2100		2200		2300		2400		2500		2600	
	HL	BL	HL	BL	HL	BL	HL	BL	HL	BL	HL	BL	HL	BL	HL	BL	HL	BL	HL	BL	HL	BL	HL	BL	HL	BL	HL	BL	HL	BL
300	-	-	-	-	-	-	-	-	-	-	-	-	-	-	-	-	-	-	-	-	-	-	-	-	-	-	-	-	-	-
350	-	-	-	-	-	-	-	-	-	-	-	-	-	-	-	-	-	-	-	-	-	-	-	-	-	-	-	-	-	-
400	-	-	-	-	-	-	-	-	-	-	-	-	-	-	-	-	-	-	-	-	-	-	-	-	-	-	-	-	-	-
450	-	-	-	-	-	-	-	-	-	-	-	-	-	-	-	-	-	-	-	-	-	-	-	-	-	-	-	-	-	-
500	-	-	-	-	-	-	-	-	-	-	-	-	-	-	-	-	-	-	-	-	-	-	-	-	-	-	-	-	-	-
600	-	-	-	-	-	-	-	-	-	-	-	-	-	-	-	-	-	-	-	-	-	-	-	-	-	-	-	-	-	-
700	-	-	-	-	-	-	-	-	-	-	-	-	-	-	-	-	-	-	-	-	-	-	-	-	-	-	-	-	-	-
800	-	-	-	-	-	-	-	-	-	-	-	-	-	-	-	-	-	-	-	-	-	-	-	-	-	-	-	-	-	-
900	-	-	-	-	-	-	-	-	-	-	-	-	-	-	-	-	-	-	-	-	-	-	-	-	-	-	-	-	-	-
1000	-	-	-	-	-	-	-	-	-	-	-	-	-	-	-	-	-	-	-	-	-	-	-	-	-	-	-	-	-	-
1100	-	-	-	-	-	-	-	-	-	-	-	-	-	-	-	-	-	-	-	-	-	-	-	-	-	-	-	-	-	-
1200	2700	1350	-	-	-	-	-	-	-	-	-	-	-	-	-	-	-	-	-	-	-	-	-	-	-	-	-	-	-	-
1300	2700	1400	2850	1450	-	-	-	-	-	-	-	-	-	-	-	-	-	-	-	-	-	-	-	-	-	-	-	-	-	-
1400	2700	1450	2850	1500	3050	1550	-	-	-	-	-	-	-	-	-	-	-	-	-	-	-	-	-	-	-	-	-	-	-	-
1500	2700	1500	2900	1550	3050	1600	3200	1650	-	-	-	-	-	-	-	-	-	-	-	-	-	-	-	-	-	-	-	-	-	-
1600	2700	1550	2900	1600	3050	1650	3250	1700	3400	1700	-	-	-	-	-	-	-	-	-	-	-	-	-	-	-	-	-	-	-	-
1700	2700	1600	2900	1650	3100	1700	3250	1750	3400	1800	3600	1800	-	-	-	-	-	-	-	-	-	-	-	-	-	-	-	-	-	-
1800	2750	1650	2900	1700	3100	1750	3250	1800	3450	1850	3600	1850	3750	1900	-	-	-	-	-	-	-	-	-	-	-	-	-	-	-	-
1900	2750	1700	2900	1750	3100	1800	3300	1850	3450	1900	3600	1950	3800	1950	3950	2000	-	-	-	-	-	-	-	-	-	-	-	-	-	-
2000	2800	1800	2900	1800	3100	1900	3300	1900	3500	2000	3700	2000	3800	2000	4000	2100	4200	2100	-	-	-	-	-	-	-	-	-	-	-	-
2100	2800	1800	2900	1900	3100	1900	3300	2000	3500	2000	3700	2100	3800	2100	4000	2100	4200	2200	4300	2200	-	-	-	-	-	-	-	-	-	-
2200	2800	1900	3000	1900	3100	2000	3300	2000	3500	2100	3700	2100	3900	2200	4000	2200	4200	2200	4400	2300	4500	2300	4500	2300	4500	2300	4500	2300	4500	2300
2300	2800	2000	3000	2000	3100	2000	3300	2100	3500	2100	3700	2200	3900	2200	4000	2200	4200	2300	4400	2400	4500	2400	4600	2400	4600	2400	4600	2400	4600	2400
2400	2800	2000	3000	2000	3100	2100	3300	2100	3500	2200	3700	2200	3900	2300	4000	2300	4200	2300	4400	2400	4500	2400	4600	2400	4600	2400	4600	2400	4600	2400
2500	2800	2100	3000	2100	3100	2100	3300	2200	3500	2200	3700	2300	3900	2300	4000	2300	4200	2400	4400	2400	4500	2400	4600	2400	4600	2400	4600	2400	4600	2400
2600	2800	2100	3000	2100	3200	2200	3400	2200	3500	2300	3700	2300	3900	2400	4100	2400	4300	2400	4400	2400	4500	2400	4600	2400	4600	2400	4600	2400	4600	2400
2700	2800	2200	3000	2200	3200	2200	3400	2300	3500	2300	3700	2400	3900	2400	4100	2400	4300	2500	4500	2500	4500	2500	4600	2500	4600	2500	4600	2500	4600	2500
2800	2800	2200	3000	2200	3200	2300	3400	2300	3500	2400	3700	2400	3900	2500	4100	2500	4300	2500	4500	2500	4500	2500	4600	2500	4600	2500	4600	2500	4600	2500
2900	2800	2300	3000	2300	3200	2300	3400	2400	3500	2400	3700	2500	3900	2500	4100	2600	4300	2600	4500	2600	4500	2600	4600	2600	4600	2600	4600	2600	4600	2600
3000	2800	2300	3000	2400	3200	2400	3400	2400	3500	2400	3700	2500	3900	2600	4100	2600	4300	2600	4500	2700	4500	2700	4600	2700	4600	2700	4600	2700	4600	2700

**Table 7-3-2 Header- and Branch Lengths Segmented Tee Pipe Series in mm – PN 1 – Stiffness Classes acc. to Table 5-1**

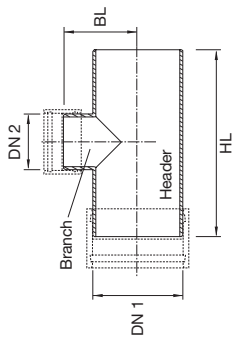

**Segmented Tees**  
**Pressure Class PN 1**  
**DN 2 = 2700 – 3000 mm**

DN 2 \ DN 1	2700		2800		2900		3000	
	HL	BL	HL	BL	HL	BL	HL	BL
300	-	-	-	-	-	-	-	-
350	-	-	-	-	-	-	-	-
400	-	-	-	-	-	-	-	-
450	-	-	-	-	-	-	-	-
500	-	-	-	-	-	-	-	-
600	-	-	-	-	-	-	-	-
700	-	-	-	-	-	-	-	-
800	-	-	-	-	-	-	-	-
900	-	-	-	-	-	-	-	-
1000	-	-	-	-	-	-	-	-
1100	-	-	-	-	-	-	-	-
1200	-	-	-	-	-	-	-	-
1300	-	-	-	-	-	-	-	-
1400	-	-	-	-	-	-	-	-
1500	-	-	-	-	-	-	-	-
1600	-	-	-	-	-	-	-	-
1700	-	-	-	-	-	-	-	-
1800	-	-	-	-	-	-	-	-
1900	-	-	-	-	-	-	-	-
2000	-	-	-	-	-	-	-	-
2100	-	-	-	-	-	-	-	-
2200	-	-	-	-	-	-	-	-
2300	-	-	-	-	-	-	-	-
2400	-	-	-	-	-	-	-	-
2500	-	-	-	-	-	-	-	-
2600	-	-	-	-	-	-	-	-
2700	4500	2300	-	-	-	-	-	-
2800	4500	2300	4600	2300	-	-	-	-
2900	4500	2400	4600	2400	4800	2400	-	-
3000	4500	2400	4600	2400	4800	2500	4900	2500

**Table 7-3-3 Header- and Branch Lengths Segmented Tee Pipe Series in mm – PN 1 – Stiffness Classes acc. to Table 5-1**

**Segmented Tees  
Pressure Class PN 6  
DN 2 = 100 – 1100 mm**

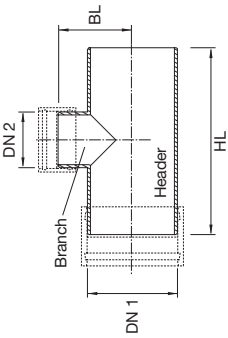

DN 2	100		150		200		250		300		350		400		450		500		600		700		800		900		1000		1100	
	HL	BL	HL	BL	HL	BL	HL	BL	HL	BL	HL	BL	HL	BL	HL	BL	HL	BL	HL	BL	HL	BL	HL	BL	HL	BL	HL	BL	HL	BL
300	720	380	780	380	820	400	900	420	1000	500	-	-	-	-	-	-	-	-	-	-	-	-	-	-	-	-	-	-	-	
350	720	400	780	400	820	420	900	460	1020	540	560	-	-	-	-	-	-	-	-	-	-	-	-	-	-	-	-	-	-	-
400	720	440	780	440	820	440	920	480	1020	560	580	1100	-	-	-	-	-	-	-	-	-	-	-	-	-	-	-	-	-	-
450	720	460	780	460	840	480	920	500	1020	580	600	1100	620	1260	640	640	640	640	640	640	640	640	640	640	640	640	640	640	640	640
500	720	480	780	480	840	500	920	520	1020	620	640	1100	640	1260	680	680	680	680	680	680	680	680	680	680	680	680	680	680	680	680
600	780	520	840	520	900	540	980	560	1080	660	680	1160	680	1260	700	700	700	700	700	700	700	700	700	700	700	700	700	700	700	700
700	800	580	860	580	920	600	980	620	1080	700	720	1160	720	1260	740	740	740	740	740	740	740	740	740	740	740	740	740	740	740	740
800	800	620	860	640	920	660	1000	680	1080	760	780	1160	780	1260	800	800	800	800	800	800	800	800	800	800	800	800	800	800	800	800
900	820	680	880	680	940	700	1000	700	1100	800	820	1180	820	1260	840	840	840	840	840	840	840	840	840	840	840	840	840	840	840	840
1000	850	750	900	750	950	750	1000	800	1100	850	900	1200	900	1300	900	900	900	900	900	900	900	900	900	900	900	900	900	900	900	900
1100	850	800	900	800	950	800	1050	850	1150	900	950	1200	950	1300	950	1000	1000	1000	1000	1000	1000	1000	1000	1000	1000	1000	1000	1000	1000	1000
1200	850	850	900	850	950	900	1050	900	1150	1000	1050	1200	1000	1300	1000	1050	1050	1050	1050	1050	1050	1050	1050	1050	1050	1050	1050	1050	1050	1050
1300	850	900	950	900	1000	950	1050	950	1150	1050	1050	1250	1050	1300	1050	1100	1100	1100	1100	1100	1100	1100	1100	1100	1100	1100	1100	1100	1100	1100
1400	900	950	950	950	1000	1000	1050	1000	1100	1100	1100	1250	1100	1300	1100	1150	1150	1150	1150	1150	1150	1150	1150	1150	1150	1150	1150	1150	1150	1150
1500	900	1000	950	1000	1000	1050	1050	1050	1150	1150	1150	1250	1150	1300	1150	1200	1200	1200	1200	1200	1200	1200	1200	1200	1200	1200	1200	1200	1200	1200
1600	950	1050	1000	1100	1050	1100	1100	1100	1150	1200	1200	1250	1200	1300	1200	1250	1250	1250	1250	1250	1250	1250	1250	1250	1250	1250	1250	1250	1250	1250
1700	950	1150	1000	1150	1050	1150	1100	1150	1150	1250	1250	1250	1250	1350	1300	1300	1300	1300	1300	1300	1300	1300	1300	1300	1300	1300	1300	1300	1300	1300
1800	1000	1200	1050	1200	1100	1200	1150	1200	1200	1300	1300	1250	1300	1350	1350	1350	1350	1350	1350	1350	1350	1350	1350	1350	1350	1350	1350	1350	1350	1350
1900	1000	1250	1050	1250	1100	1250	1150	1250	1200	1350	1350	1250	1350	1400	1400	1400	1400	1400	1400	1400	1400	1400	1400	1400	1400	1400	1400	1400	1400	1400
2000	1000	1300	1100	1300	1100	1300	1200	1300	1300	1400	1300	1300	1400	1500	1500	1500	1500	1500	1500	1500	1500	1500	1500	1500	1500	1500	1500	1500	1500	1500
2100	1100	1400	1100	1400	1200	1400	1200	1400	1300	1500	1300	1300	1500	1600	1600	1600	1600	1600	1600	1600	1600	1600	1600	1600	1600	1600	1600	1600	1600	1600
2200	1100	1400	1100	1400	1200	1400	1200	1400	1300	1500	1300	1300	1500	1600	1600	1600	1600	1600	1600	1600	1600	1600	1600	1600	1600	1600	1600	1600	1600	1600
2300	1100	1500	1200	1500	1200	1500	1300	1500	1300	1600	1400	1400	1600	1700	1700	1700	1700	1700	1700	1700	1700	1700	1700	1700	1700	1700	1700	1700	1700	1700
2400	1100	1500	1200	1500	1200	1500	1300	1600	1300	1600	1400	1400	1600	1700	1700	1700	1700	1700	1700	1700	1700	1700	1700	1700	1700	1700	1700	1700	1700	1700
2500	1100	1600	1200	1600	1200	1600	1300	1600	1400	1700	1400	1400	1600	1700	1700	1700	1700	1700	1700	1700	1700	1700	1700	1700	1700	1700	1700	1700	1700	1700
2600	1200	1600	1200	1600	1300	1600	1300	1700	1400	1700	1400	1400	1600	1800	1800	1800	1800	1800	1800	1800	1800	1800	1800	1800	1800	1800	1800	1800	1800	1800
2700	1200	1700	1300	1700	1300	1700	1400	1700	1400	1800	1400	1400	1600	1800	1800	1800	1800	1800	1800	1800	1800	1800	1800	1800	1800	1800	1800	1800	1800	1800
2800	1200	1700	1300	1700	1300	1800	1400	1800	1400	1800	1400	1400	1600	1900	1900	1900	1900	1900	1900	1900	1900	1900	1900	1900	1900	1900	1900	1900	1900	1900
2900	1300	1800	1300	1800	1400	1800	1400	1800	1500	1900	1600	1600	1800	1900	1900	1900	1900	1900	1900	1900	1900	1900	1900	1900	1900	1900	1900	1900	1900	1900
3000	1300	1800	1300	1800	1400	1900	1400	1900	1500	2000	1600	1600	1800	2000	2000	2000	2000	2000	2000	2000	2000	2000	2000	2000	2000	2000	2000	2000	2000	2000

**Table 7-3-4 Header- and Branch Lengths Segmented Tee Pipe Series in mm – PN 6 – Stiffness Classes acc. to Table 5-1**

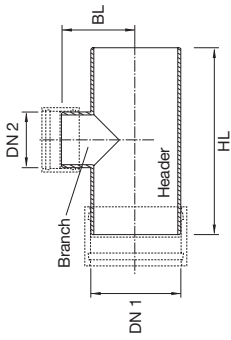

**Segmented Tees  
Pressure Class PN 6  
DN 2 = 1200 – 2600 mm**

DN 2 \ DN 1	1200		1300		1400		1500		1600		1700		1800		1900		2000		2100		2200		2300		2400		2500		2600			
	HL	BL	HL	BL	HL	BL	HL	BL	HL	BL	HL	BL	HL	BL	HL	BL	HL	BL	HL	BL	HL	BL	HL	BL	HL	BL	HL	BL	HL	BL		
300	-	-	-	-	-	-	-	-	-	-	-	-	-	-	-	-	-	-	-	-	-	-	-	-	-	-	-	-	-	-		
350	-	-	-	-	-	-	-	-	-	-	-	-	-	-	-	-	-	-	-	-	-	-	-	-	-	-	-	-	-	-		
400	-	-	-	-	-	-	-	-	-	-	-	-	-	-	-	-	-	-	-	-	-	-	-	-	-	-	-	-	-	-		
450	-	-	-	-	-	-	-	-	-	-	-	-	-	-	-	-	-	-	-	-	-	-	-	-	-	-	-	-	-	-		
500	-	-	-	-	-	-	-	-	-	-	-	-	-	-	-	-	-	-	-	-	-	-	-	-	-	-	-	-	-	-		
600	-	-	-	-	-	-	-	-	-	-	-	-	-	-	-	-	-	-	-	-	-	-	-	-	-	-	-	-	-	-		
700	-	-	-	-	-	-	-	-	-	-	-	-	-	-	-	-	-	-	-	-	-	-	-	-	-	-	-	-	-	-		
800	-	-	-	-	-	-	-	-	-	-	-	-	-	-	-	-	-	-	-	-	-	-	-	-	-	-	-	-	-	-		
900	-	-	-	-	-	-	-	-	-	-	-	-	-	-	-	-	-	-	-	-	-	-	-	-	-	-	-	-	-	-		
1000	-	-	-	-	-	-	-	-	-	-	-	-	-	-	-	-	-	-	-	-	-	-	-	-	-	-	-	-	-	-		
1100	-	-	-	-	-	-	-	-	-	-	-	-	-	-	-	-	-	-	-	-	-	-	-	-	-	-	-	-	-	-		
1200	2700	1350	-	-	-	-	-	-	-	-	-	-	-	-	-	-	-	-	-	-	-	-	-	-	-	-	-	-	-	-		
1300	2700	1400	2850	1450	-	-	-	-	-	-	-	-	-	-	-	-	-	-	-	-	-	-	-	-	-	-	-	-	-	-		
1400	2700	1450	2850	1500	3050	1550	-	-	-	-	-	-	-	-	-	-	-	-	-	-	-	-	-	-	-	-	-	-	-	-		
1500	2700	1500	2900	1550	3050	1600	3200	1650	-	-	-	-	-	-	-	-	-	-	-	-	-	-	-	-	-	-	-	-	-	-		
1600	2700	1550	2900	1600	3050	1650	3250	1700	3400	1700	-	-	-	-	-	-	-	-	-	-	-	-	-	-	-	-	-	-	-	-		
1700	2700	1600	2900	1650	3100	1700	3250	1750	3400	1800	3600	1800	-	-	-	-	-	-	-	-	-	-	-	-	-	-	-	-	-	-		
1800	2750	1650	2900	1700	3100	1750	3250	1800	3450	1850	3600	1850	3750	1900	-	-	-	-	-	-	-	-	-	-	-	-	-	-	-	-		
1900	2750	1700	2900	1750	3100	1800	3300	1850	3450	1900	3600	1950	3800	1950	3950	2000	-	-	-	-	-	-	-	-	-	-	-	-	-	-		
2000	2800	1800	2900	1800	3100	1900	3300	1900	3500	2000	3700	2000	3800	2000	4000	2100	4200	2100	-	-	-	-	-	-	-	-	-	-	-	-		
2100	2800	1800	2900	1900	3100	1900	3300	2000	3500	2000	3700	2100	3800	2100	4000	2100	4200	2200	4300	2200	-	-	-	-	-	-	-	-	-	-		
2200	2800	1900	3000	1900	3100	2000	3300	2000	3500	2100	3700	2100	3900	2200	4000	2200	4200	2200	4400	2300	4500	2300	-	-	-	-	-	-	-	-		
2300	2800	2000	3000	2000	3100	2000	3300	2100	3500	2100	3700	2200	3900	2200	4000	2200	4200	2300	4400	2400	4500	2400	4600	2400	-	-	-	-	-	-		
2400	2800	2000	3000	2000	3100	2100	3300	2100	3500	2200	3700	2200	3900	2300	4000	2300	4200	2300	4400	2400	4500	2400	4600	2400	4700	2400	4900	2500	-	-		
2500	2800	2100	3000	2100	3100	2100	3300	2200	3500	2200	3700	2300	3900	2300	4000	2300	4200	2400	4400	2400	4500	2400	4600	2500	4700	2500	4900	2500	5100	2600	-	
2600	2800	2100	3000	2100	3200	2200	3400	2200	3500	2300	3700	2300	3900	2400	4100	2400	4300	2400	4400	2500	4500	2500	4600	2500	4800	2600	5000	2600	5300	2700	-	
2700	2800	2200	3000	2200	3200	2200	3400	2300	3500	2300	3700	2400	3900	2400	4100	2400	4300	2500	4500	2500	4600	2600	2600	4800	2600	5000	2600	5300	2700	-	-	
2800	2800	2200	3000	2200	3200	2300	3400	2300	3500	2400	3700	2400	3900	2500	4100	2500	4300	2500	4500	2600	4600	2600	4800	2700	4800	2700	5000	2700	5300	2800	-	
2900	2800	2300	3000	2300	3200	2300	3400	2400	3500	2400	3700	2500	3900	2500	4100	2600	4300	2600	4500	2600	4600	2700	2700	4800	2700	5000	2800	5300	2800	-	-	
3000	2800	2300	3000	2400	3200	2400	3400	2400	3500	2400	3700	2500	3900	2600	4100	2600	4300	2600	4500	2700	4600	2700	2800	4800	2800	5000	2800	5300	2800	5400	2900	-

**Table 7-3-5 Header- and Branch Lengths Segmented Tee Pipe Series in mm – PN 6 – Stiffness Classes acc. to Table 5-1**

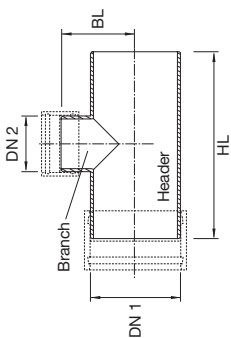

**Segmented Tees**  
**Pressure Class PN 6**  
**DN 2 = 2700 – 3000 mm**

DN 1 \ DN 2	2700		2800		2900		3000	
	HL	BL	HL	BL	HL	BL	HL	BL
300	-	-	-	-	-	-	-	-
350	-	-	-	-	-	-	-	-
400	-	-	-	-	-	-	-	-
450	-	-	-	-	-	-	-	-
500	-	-	-	-	-	-	-	-
600	-	-	-	-	-	-	-	-
700	-	-	-	-	-	-	-	-
800	-	-	-	-	-	-	-	-
900	-	-	-	-	-	-	-	-
1000	-	-	-	-	-	-	-	-
1100	-	-	-	-	-	-	-	-
1200	-	-	-	-	-	-	-	-
1300	-	-	-	-	-	-	-	-
1400	-	-	-	-	-	-	-	-
1500	-	-	-	-	-	-	-	-
1600	-	-	-	-	-	-	-	-
1700	-	-	-	-	-	-	-	-
1800	-	-	-	-	-	-	-	-
1900	-	-	-	-	-	-	-	-
2000	-	-	-	-	-	-	-	-
2100	-	-	-	-	-	-	-	-
2200	-	-	-	-	-	-	-	-
2300	-	-	-	-	-	-	-	-
2400	-	-	-	-	-	-	-	-
2500	-	-	-	-	-	-	-	-
2600	-	-	-	-	-	-	-	-
2700	5400	2700	-	-	-	-	-	-
2800	5500	2800	5600	2800	-	-	-	-
2900	5500	2900	5700	2900	5800	2900	-	-
3000	5500	2900	5700	3000	5900	3000	6000	3000

**Table 7-3-6 Header- and Branch Lengths Segmented Tee Pipe Series in mm – PN 6 – Stiffness Classes acc. to Table 5-1**

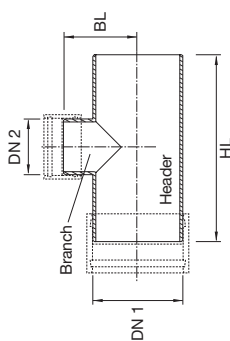

**Segmented Tees**  
**Pressure Class PN 10**  
**DN 2 = 100 – 1100 mm**

DN 2 \ DN 1	100		150		200		250		300		350		400		450		500		600		700		800		900		1000		1100	
	HL	BL	HL	BL	HL	BL	HL	BL	HL	BL	HL	BL	HL	BL	HL	BL	HL	BL	HL	BL	HL	BL	HL	BL	HL	BL	HL	BL	HL	BL
300	720	380	800	400	860	420	940	440	1040	520	-	-	-	-	-	-	-	-	-	-	-	-	-	-	-	-	-	-	-	
350	720	400	800	420	860	440	940	460	1040	560	1120	580	-	-	-	-	-	-	-	-	-	-	-	-	-	-	-	-	-	-
400	740	440	800	440	860	460	940	500	1040	580	1140	600	1220	620	-	-	-	-	-	-	-	-	-	-	-	-	-	-	-	-
450	740	460	800	480	860	500	940	520	1060	600	1140	620	1240	640	1320	660	-	-	-	-	-	-	-	-	-	-	-	-	-	-
500	740	500	800	500	860	520	960	540	1060	640	1140	660	1240	680	1320	700	1400	720	-	-	-	-	-	-	-	-	-	-	-	-
600	820	540	880	540	940	560	1020	580	1120	680	1200	700	1320	720	1400	740	1500	760	820	1640	820	-	-	-	-	-	-	-	-	-
700	820	600	880	600	940	620	1020	640	1140	720	1220	760	1320	780	1400	800	1500	820	1660	900	1840	920	-	-	-	-	-	-	-	-
800	820	640	900	640	960	660	1040	700	1140	780	1220	800	1320	820	1420	860	1500	860	1660	940	1860	980	1020	-	-	-	-	-	-	-
900	840	700	900	700	960	720	1040	740	1140	840	1240	860	1320	880	1420	900	1500	920	1680	1000	1900	1040	1080	2060	1080	2220	1120	-	-	-
1000	850	750	950	750	1000	800	1050	800	1150	900	1250	950	1350	950	1450	950	1550	1000	1700	1050	1950	1100	1150	2050	1150	2250	1200	2450	1250	-
1100	850	800	950	800	1000	850	1050	850	1200	950	1250	1000	1350	1000	1450	1000	1550	1050	1700	1100	1900	1150	1200	2100	1200	2250	1250	2450	1300	1300
1200	900	850	950	900	1000	900	1100	900	1200	1000	1250	1050	1350	1050	1450	1100	1550	1100	1700	1150	1900	1200	1250	2100	1250	2300	1300	2450	1350	1400
1300	900	950	950	950	1000	950	1100	950	1200	1050	1300	1100	1350	1100	1450	1150	1550	1150	1700	1200	1900	1250	1300	2100	1300	2300	1350	2450	1400	1450
1400	900	1000	950	1000	1050	1000	1100	1050	1200	1100	1300	1150	1400	1150	1450	1200	1550	1200	1700	1250	1950	1300	1350	2100	1350	2300	1400	2500	1450	1500
1500	950	1050	1000	1050	1050	1050	1100	1100	1200	1150	1300	1200	1400	1200	1500	1250	1550	1250	1750	1350	1950	1350	1400	2100	1400	2300	1450	2500	1500	1550
1600	950	1100	1000	1100	1050	1100	1150	1150	1250	1200	1300	1250	1400	1250	1500	1300	1600	1300	1750	1400	1950	1450	1500	2100	1450	2300	1500	2500	1550	1600
1700	1000	1150	1050	1150	1100	1150	1200	1200	1300	1250	1350	1300	1400	1300	1500	1350	1600	1350	1750	1450	1950	1450	1500	2100	1500	2300	1550	2500	1600	1650
1800	1000	1200	1050	1200	1100	1200	1250	1250	1350	1350	1400	1350	1400	1350	1500	1400	1600	1400	1750	1500	1950	1500	1550	2150	1550	2300	1600	2500	1650	1700
1900	1050	1250	1100	1250	1150	1250	1300	1300	1400	1400	1400	1300	1400	1400	1500	1450	1600	1450	1750	1550	1950	1550	1600	2150	1600	2350	1650	2500	1700	1750
2000	1100	1300	1100	1300	1200	1400	1200	1400	1300	1500	1400	1500	1500	1500	1500	1500	1600	1500	1800	1600	2000	1700	1700	2200	1700	2400	1700	2500	1800	1800
2100	1100	1400	1200	1400	1200	1400	1300	1400	1300	1500	1400	1500	1600	1600	1600	1600	1700	1600	1800	1700	2000	1700	1800	2200	1800	2400	1800	2500	1900	1900
2200	1100	1400	1200	1400	1200	1500	1300	1300	1300	1600	1400	1400	1600	1600	1600	1600	1700	1600	1800	1700	2000	1800	1800	2200	1800	2400	1900	2600	1900	1900
2300	1100	1500	1200	1500	1300	1500	1300	1300	1400	1600	1400	1400	1600	1600	1600	1700	1700	1700	1800	1800	2000	1800	1900	2200	1900	2400	1900	2600	1900	2000
2400	1200	1600	1200	1600	1300	1600	1300	1300	1400	1700	1400	1400	1700	1500	1700	1700	1700	1800	1800	1900	2000	1900	1900	2200	1900	2400	2000	2600	2000	2000

**Table 7-3-7 Header- and Branch Lengths Segmented Tee Pipe Series in mm – PN 10 – Stiffness Classes acc. to Table 5-1**

**Segmented Tees  
Pressure Class PN 10  
DN 2 = 1200 – 2400 mm**

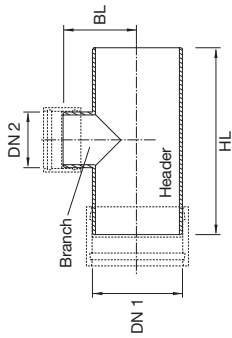

DN 2	1200		1300		1400		1500		1600		1700		1800		1900		2000		2100		2200		2300		2400	
	HL	BL	HL	BL	HL	BL	HL	BL	HL	BL	HL	BL	HL	BL	HL	BL	HL	BL	HL	BL	HL	BL	HL	BL	HL	BL
300	-	-	-	-	-	-	-	-	-	-	-	-	-	-	-	-	-	-	-	-	-	-	-	-	-	-
350	-	-	-	-	-	-	-	-	-	-	-	-	-	-	-	-	-	-	-	-	-	-	-	-	-	-
400	-	-	-	-	-	-	-	-	-	-	-	-	-	-	-	-	-	-	-	-	-	-	-	-	-	-
450	-	-	-	-	-	-	-	-	-	-	-	-	-	-	-	-	-	-	-	-	-	-	-	-	-	-
500	-	-	-	-	-	-	-	-	-	-	-	-	-	-	-	-	-	-	-	-	-	-	-	-	-	-
600	-	-	-	-	-	-	-	-	-	-	-	-	-	-	-	-	-	-	-	-	-	-	-	-	-	-
700	-	-	-	-	-	-	-	-	-	-	-	-	-	-	-	-	-	-	-	-	-	-	-	-	-	-
800	-	-	-	-	-	-	-	-	-	-	-	-	-	-	-	-	-	-	-	-	-	-	-	-	-	-
900	-	-	-	-	-	-	-	-	-	-	-	-	-	-	-	-	-	-	-	-	-	-	-	-	-	-
1000	-	-	-	-	-	-	-	-	-	-	-	-	-	-	-	-	-	-	-	-	-	-	-	-	-	-
1100	-	-	-	-	-	-	-	-	-	-	-	-	-	-	-	-	-	-	-	-	-	-	-	-	-	-
1200	2800	1400	-	-	-	-	-	-	-	-	-	-	-	-	-	-	-	-	-	-	-	-	-	-	-	-
1300	2850	1500	3000	1500	-	-	-	-	-	-	-	-	-	-	-	-	-	-	-	-	-	-	-	-	-	-
1400	2850	1550	3000	1550	1600	1600	-	-	-	-	-	-	-	-	-	-	-	-	-	-	-	-	-	-	-	-
1500	2850	1600	3050	1650	1650	1650	3400	1700	-	-	-	-	-	-	-	-	-	-	-	-	-	-	-	-	-	-
1600	2900	1650	3050	1700	1750	1750	3400	1800	1800	1800	-	-	-	-	-	-	-	-	-	-	-	-	-	-	-	-
1700	2900	1700	3050	1750	1800	1800	3450	1850	1850	1850	1900	1900	1900	1900	1900	1900	1900	1900	1900	1900	1900	1900	1900	1900	1900	1900
1800	2900	1750	3100	1800	1850	1850	3450	1900	1950	1950	2000	2000	2000	2000	2000	2000	2000	2000	2000	2000	2000	2000	2000	2000	2000	2000
1900	2900	1800	3100	1850	1900	1900	3450	1950	2000	2000	2050	2050	2050	2050	2050	2050	2050	2050	2050	2050	2050	2050	2050	2050	2050	2050
2000	2900	1900	3100	1900	1900	1900	3500	2000	2000	2000	2100	2100	2100	2100	2100	2100	2100	2100	2100	2100	2100	2100	2100	2100	2100	2100
2100	2900	1900	3100	2000	2000	2000	3500	2100	2100	2100	2200	2200	2200	2200	2200	2200	2200	2200	2200	2200	2200	2200	2200	2200	2200	2200
2200	2900	2000	3100	2000	2000	2000	3500	2100	2100	2100	2200	2200	2200	2200	2200	2200	2200	2200	2200	2200	2200	2200	2200	2200	2200	2200
2300	2900	2000	3100	2100	2100	2100	3500	2200	2200	2200	2300	2300	2300	2300	2300	2300	2300	2300	2300	2300	2300	2300	2300	2300	2300	2300
2400	2900	2100	3100	2100	2100	2100	3500	2200	2200	2200	2300	2300	2300	2300	2300	2300	2300	2300	2300	2300	2300	2300	2300	2300	2300	2300

**Table 7-3-8 Header and Branch Lengths Segmented Tee Pipe Series in mm – PN 10 – Stiffness Classes acc. to Table 5-1**

Other Diameters on Request

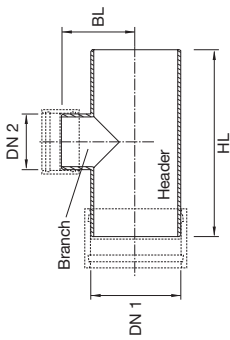

**Segmented Tees**  
**Pressure Class PN 16**  
**DN 2 = 100 – 1100 mm**

DN 2 \ DN 1	100		150		200		250		300		350		400		450		500		600		700		800		900		1000		1100		
	HL	BL	HL	BL	HL	BL	HL	BL	HL	BL	HL	BL	HL	BL	HL	BL	HL	BL	HL	BL	HL	BL	HL	BL	HL	BL	HL	BL	HL	BL	
300	740	400	820	400	900	440	980	460	1080	540	-	-	-	-	-	-	-	-	-	-	-	-	-	-	-	-	-	-	-	-	
350	760	420	820	440	900	460	1000	500	1100	580	1180	600	1280	640	1380	700	1500	760	1740	880	1940	980	2000	1150	2200	1200	2550	1300	2800	1400	
400	760	460	820	460	900	480	1000	520	1100	600	1180	620	1280	680	1300	700	1500	760	1740	880	1940	980	2000	1150	2200	1200	2550	1300	2800	1400	
450	760	480	840	480	900	500	1000	540	1120	640	1200	660	1220	700	1300	700	1400	740	1500	760	1740	880	1940	980	2000	1150	2200	1200	2550	1300	2800
500	780	500	840	520	900	540	1000	560	1120	660	1200	680	1220	700	1300	740	1500	760	1740	880	1940	980	2000	1150	2200	1200	2550	1300	2800	1400	
600	840	560	920	560	980	580	1060	620	1180	700	1280	740	1380	760	1380	760	1480	800	1560	800	1740	880	1940	980	2000	1150	2200	1200	2550	1300	2800
700	860	620	920	620	1000	640	1080	660	1200	760	1280	780	1380	800	1500	840	1580	860	1740	880	1940	980	2000	1150	2200	1200	2550	1300	2800	1400	
800	860	660	960	680	1000	700	1100	720	1200	800	1300	840	1400	860	1500	900	1600	920	1760	960	1960	1040	1980	1100	2200	1200	2550	1300	2800	1400	
900	880	720	960	720	1020	740	1100	780	1220	860	1320	900	1400	920	1500	940	1600	960	1760	960	1960	1040	1980	1100	2200	1200	2550	1300	2800	1400	
1000	900	800	1000	800	1050	800	1150	850	1250	950	1350	950	1450	1000	1550	1000	1600	1050	1800	1050	1980	1100	2000	1150	2200	1200	2550	1300	2800	1400	
1100	950	850	1000	850	1050	900	1150	900	1250	1000	1350	1000	1450	1050	1550	1050	1650	1100	1800	1100	1980	1150	2000	1200	2200	1250	2600	1350	2800	1400	
1200	950	900	1000	900	1100	950	1150	950	1250	1050	1350	1050	1450	1100	1550	1100	1650	1150	1800	1150	1980	1200	2050	1250	2200	1300	2600	1400	2800	1450	
1300	950	950	1050	950	1100	1000	1200	1000	1250	1100	1350	1150	1450	1150	1550	1150	1650	1200	1800	1200	1980	1250	2050	1350	2250	1400	2600	1450	2800	1500	
1400	1000	1000	1050	1000	1100	1050	1200	1050	1300	1150	1400	1200	1500	1200	1550	1250	1650	1250	1850	1250	1980	1300	2050	1400	2250	1450	2650	1550	2850	1600	
1500	1000	1050	1100	1100	1150	1100	1200	1150	1300	1200	1400	1250	1500	1250	1600	1300	1700	1300	1850	1300	1980	1350	2050	1450	2250	1500	2650	1600	2850	1650	
1600	1050	1150	1100	1150	1150	1150	1250	1200	1300	1250	1400	1300	1500	1300	1600	1350	1700	1350	1850	1350	1980	1400	2050	1450	2250	1550	2650	1650	2850	1700	
1700	1050	1200	1100	1200	1200	1250	1250	1250	1350	1350	1400	1400	1500	1350	1600	1400	1700	1400	1900	1400	1980	1450	2100	1550	2300	1600	2650	1700	2900	1750	
1800	1100	1250	1150	1250	1200	1300	1300	1300	1350	1350	1400	1450	1500	1450	1600	1450	1700	1450	1900	1450	1980	1500	2100	1600	2300	1650	2700	1750	2900	1800	
1900	1100	1300	1200	1350	1250	1350	1350	1350	1350	1350	1450	1450	1500	1500	1650	1500	1750	1550	1900	1500	1980	1600	2100	1650	2300	1700	2700	1800	2900	1850	
2000	1200	1400	1200	1400	1300	1400	1300	1300	1400	1500	1500	1500	1600	1600	1700	1600	1800	1600	1900	1600	1980	1700	2100	1700	2300	1800	2700	1900	2900	1900	

**Table 7-3-9 Header- and Branch Lengths Segmented Tee Pipe Series in mm – PN 16 – Stiffness Classes acc. to Table 5-1**

**Segmented Tees**  
**Pressure Class PN 16**  
**DN 2 = 1200 – 2000 mm**

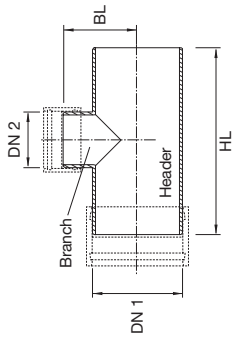

DN 2 \ DN 1	1200		1300		1400		1500		1600		1700		1800		1900		2000	
	HL	BL	HL	BL	HL	BL	HL	BL	HL	BL	HL	BL	HL	BL	HL	BL	HL	BL
300	-	-	-	-	-	-	-	-	-	-	-	-	-	-	-	-	-	-
350	-	-	-	-	-	-	-	-	-	-	-	-	-	-	-	-	-	-
400	-	-	-	-	-	-	-	-	-	-	-	-	-	-	-	-	-	-
450	-	-	-	-	-	-	-	-	-	-	-	-	-	-	-	-	-	-
500	-	-	-	-	-	-	-	-	-	-	-	-	-	-	-	-	-	-
600	-	-	-	-	-	-	-	-	-	-	-	-	-	-	-	-	-	-
700	-	-	-	-	-	-	-	-	-	-	-	-	-	-	-	-	-	-
800	-	-	-	-	-	-	-	-	-	-	-	-	-	-	-	-	-	-
900	-	-	-	-	-	-	-	-	-	-	-	-	-	-	-	-	-	-
1000	-	-	-	-	-	-	-	-	-	-	-	-	-	-	-	-	-	-
1100	-	-	-	-	-	-	-	-	-	-	-	-	-	-	-	-	-	-
1200	3000	1500	-	-	-	-	-	-	-	-	-	-	-	-	-	-	-	-
1300	3000	1550	3200	1600	-	-	-	-	-	-	-	-	-	-	-	-	-	-
1400	3000	1600	3200	1650	3400	1700	-	-	-	-	-	-	-	-	-	-	-	-
1500	3050	1700	3250	1750	3450	1750	3600	1850	-	-	-	-	-	-	-	-	-	-
1600	3050	1750	3250	1800	3450	1850	3650	1900	3800	1950	-	-	-	-	-	-	-	-
1700	3050	1800	3250	1850	3450	1900	3650	1950	3850	2000	4000	2050	-	-	-	-	-	-
1800	3100	1850	3250	1900	3500	1950	3650	2000	3850	2050	4050	2100	4250	2150	-	-	-	-
1900	3100	1900	3300	1950	3500	2000	3700	2050	3850	2100	4100	2150	4250	2200	4450	2250	-	-
2000	3100	2000	3300	2000	3500	2100	3700	2100	3900	2200	4100	2200	4300	2300	4500	2300	4700	2400

**Table 7-3-10 Header- and Branch Lengths Segmented Tee Pipe Series in mm – PN 16 – Stiffness Classes acc. to Table 5-1**

Other Diameters on Request

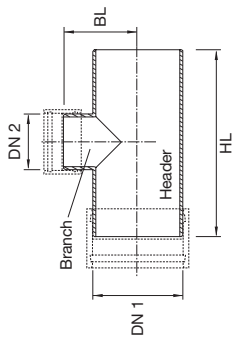

**Segmented Tees  
Pressure Class PN 20  
DN 2 = 100 – 1100 mm**

DN 2 \ DN 1		100		150		200		250		300		350		400		450		500		600		700		800		900		1000		1100					
DN 1	HL	BL	HL	BL	HL	BL	HL	BL	HL	BL	HL	BL	HL	BL	HL	BL	HL	BL	HL	BL	HL	BL	HL	BL	HL	BL	HL	BL	HL	BL					
300	760	400	840	420	920	440	1020	480	1120	560	1220	620	1320	660	1440	720	1540	780	1620	840	1800	900	2020	1020	2220	1120	2460	1240	2500	1300	2700	1400	2900	1450	1650
350	780	440	840	440	920	480	1020	500	1140	600	1240	660	1340	700	1440	760	1540	820	1640	880	1820	960	2040	1080	2240	1180	2480	1300	2520	1360	2720	1460	2920	1500	1600
400	780	460	860	480	940	500	1020	520	1140	620	1240	680	1340	720	1440	780	1540	840	1640	900	1840	960	2060	1080	2260	1180	2500	1240	2560	1300	2760	1400	2950	1500	1600
450	800	500	860	500	940	520	1040	560	1140	660	1240	720	1340	760	1440	820	1540	880	1640	940	1860	1000	2080	1120	2280	1220	2520	1280	2580	1340	2780	1450	2950	1500	1650
500	800	520	880	540	960	560	1040	600	1140	680	1260	740	1360	780	1440	840	1540	900	1620	960	1880	1020	2100	1140	2300	1240	2560	1300	2600	1360	2780	1450	2950	1500	1650
600	880	560	940	580	1020	600	1120	640	1220	720	1320	760	1440	800	1520	860	1620	920	1700	980	1900	1050	2120	1160	2320	1260	2600	1320	2640	1380	2820	1450	2950	1500	1650
700	880	620	980	640	1040	660	1120	700	1240	780	1340	820	1440	860	1540	920	1640	980	1740	1040	1920	1100	2140	1200	2340	1300	2600	1360	2640	1420	2820	1450	2950	1500	1650
800	920	680	980	700	1040	720	1140	740	1260	840	1360	880	1460	920	1560	980	1660	1040	1760	1100	1960	1150	2160	1250	2360	1350	2600	1400	2640	1460	2820	1450	2950	1500	1650
900	920	740	1000	760	1060	780	1160	800	1260	900	1360	920	1460	940	1580	980	1680	1040	1780	1100	1980	1150	2180	1250	2380	1350	2600	1400	2640	1460	2820	1450	2950	1500	1650
1000	950	800	1050	850	1100	850	1200	900	1300	950	1400	1000	1500	1000	1600	1050	1700	1100	1800	1150	1950	1200	2200	1300	2400	1350	2600	1400	2640	1460	2820	1450	2950	1500	1650
1100	1000	900	1050	900	1150	900	1250	950	1350	1000	1450	1050	1550	1100	1650	1100	1750	1150	1850	1200	1950	1250	2250	1350	2450	1400	2600	1450	2640	1500	2820	1450	2950	1500	1650
1200	1000	950	1100	950	1150	1000	1250	1000	1350	1100	1450	1100	1550	1150	1650	1150	1750	1200	1850	1250	1950	1300	2250	1400	2450	1450	2600	1500	2640	1550	2820	1450	2950	1500	1650
1300	1050	1000	1100	1000	1200	1050	1250	1050	1350	1150	1450	1150	1550	1200	1650	1200	1750	1250	1850	1300	1950	1350	2250	1450	2450	1500	2600	1550	2640	1600	2820	1450	2950	1500	1650
1400	1050	1050	1150	1100	1200	1100	1300	1150	1400	1200	1450	1200	1550	1250	1650	1250	1750	1300	1850	1350	1950	1400	2250	1500	2450	1550	2600	1600	2640	1650	2820	1450	2950	1500	1650

**Table 7-3-11 Header- and Branch Lengths Segmented Tee Pipe Series in mm – PN 20 – Stiffness Classes acc. to Table 5-1**

**Segmented Tees**  
**Pressure Class PN 20**  
**DN 2 = 1200 – 1400 mm**

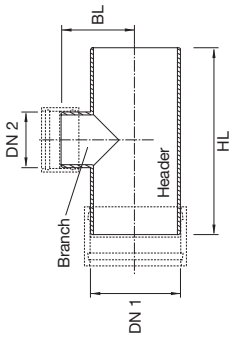

DN 1 \ DN 2	1200		1300		1400	
	HL	BL	HL	BL	HL	BL
300	-	-	-	-	-	-
350	-	-	-	-	-	-
400	-	-	-	-	-	-
450	-	-	-	-	-	-
500	-	-	-	-	-	-
600	-	-	-	-	-	-
700	-	-	-	-	-	-
800	-	-	-	-	-	-
900	-	-	-	-	-	-
1000	-	-	-	-	-	-
1100	-	-	-	-	-	-
1200	3100	1550	-	-	-	-
1300	3150	1650	3300	1700	-	-
1400	3150	1700	3350	1750	3550	1800

**Table 7-3-12 Header and Branch Lengths Segmented Tee Pipe Series in mm – PN 20 – Stiffness Classes acc. to Table 5-1**

Other Diameters on Request

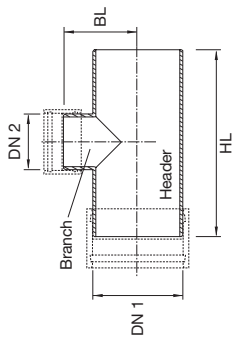

**Segmented Tees**  
**Pressure Class PN 25**  
**DN 2 = 100 – 1100 mm**

DN 2 \ DN 1	100		150		200		250		300		350		400		450		500		600		700		800		900		1000		1100		
	HL	BL	HL	BL	HL	BL	HL	BL	HL	BL	HL	BL	HL	BL	HL	BL	HL	BL	HL	BL	HL	BL	HL	BL	HL	BL	HL	BL			
300	780	420	880	440	960	460	1040	500	1160	580	640	1260	680	700	1400	720	1480	760	800	1860	940	2080	2120	2320	2360	1240	2540	2600	1350	1400	1500
350	800	460	880	460	960	480	1060	520	1160	620	680	1280	720	1360	1400	740	1500	820	860	1860	940	2080	2120	2320	2360	1240	2540	2600	1350	1400	1500
400	820	480	900	500	980	520	1080	560	1180	640	700	1280	740	1360	1400	760	1500	800	840	1860	940	2080	2120	2320	2360	1240	2540	2600	1350	1400	1500
450	820	500	900	520	980	540	1080	580	1200	680	740	1320	740	1420	1400	760	1500	800	840	1860	940	2080	2120	2320	2360	1240	2540	2600	1350	1400	1500
500	840	540	920	560	980	580	1080	620	1200	700	740	1320	740	1420	1400	760	1500	800	840	1860	940	2080	2120	2320	2360	1240	2540	2600	1350	1400	1500
600	900	580	1000	600	1080	640	1160	660	1280	740	780	1380	780	1500	1500	820	1600	860	860	1860	940	2080	2120	2320	2360	1240	2540	2600	1350	1400	1500
700	920	640	1000	660	1100	700	1200	720	1300	820	840	1400	840	1500	1500	860	1620	920	920	1900	1000	2080	2120	2320	2360	1240	2540	2600	1350	1400	1500
800	960	700	1040	720	1120	760	1220	780	1320	880	900	1440	900	1520	1500	920	1640	980	980	1920	1060	2120	2160	2320	2360	1240	2540	2600	1350	1400	1500
900	980	780	1080	800	1160	840	1260	860	1360	940	960	1460	960	1540	1500	1000	1640	1040	1040	1940	1140	2160	2160	2320	2360	1240	2540	2600	1350	1400	1500
1000	1050	850	1100	850	1200	900	1300	950	1400	1000	1050	1500	1050	1600	1600	1050	1700	1100	1100	2000	1200	2200	2200	2400	2400	1300	2600	2600	1350	1400	1500
1100	1050	900	1150	950	1250	950	1350	1000	1400	1100	1100	1500	1100	1600	1600	1150	1700	1150	1150	2000	1250	2250	2250	2450	2450	1300	2650	2650	1350	1400	1500
1200	1100	1000	1200	1000	1300	1050	1350	1050	1450	1150	1150	1550	1150	1650	1650	1200	1750	1250	1250	2000	1300	2250	2250	2450	2450	1350	2650	2650	1350	1400	1500
1300	1150	1050	1250	1050	1300	1100	1400	1150	1500	1200	1200	1600	1200	1650	1650	1250	1750	1300	1300	2050	1350	2250	2250	2450	2450	1400	2650	2650	1350	1400	1500
1400	1200	1150	1250	1150	1350	1150	1450	1200	1500	1250	1250	1600	1300	1700	1700	1300	1800	1350	1350	2050	1450	2250	2250	2450	2450	1450	2650	2650	1350	1400	1500

**Table 7-3-13 Header- and Branch Lengths Segmented Tee Pipe Series in mm – PN 25 – Stiffness Classes acc. to Table 5-1**

**Segmented Tees**  
**Pressure Class PN 25**  
**DN 2 = 1200 – 1400 mm**

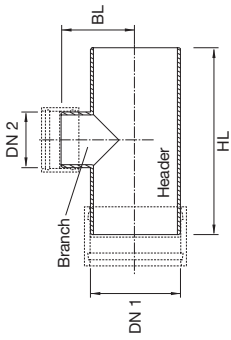

DN 1 \ DN 2		1200		1300		1400	
		HL	BL	HL	BL	HL	BL
300	300	-	-	-	-	-	-
350	350	-	-	-	-	-	-
400	400	-	-	-	-	-	-
450	450	-	-	-	-	-	-
500	500	-	-	-	-	-	-
600	600	-	-	-	-	-	-
700	700	-	-	-	-	-	-
800	800	-	-	-	-	-	-
900	900	-	-	-	-	-	-
1000	1000	-	-	-	-	-	-
1100	1100	-	-	-	-	-	-
1200	1200	3250	1650	-	-	-	-
1300	1300	3300	1700	3450	1750	-	-
1400	1400	3300	1750	3500	1800	3700	1850

**Table 7-3-14 Header- and Branch Lengths Segmented Tee Pipe Series in mm – PN 25 – Stiffness Classes acc. to Table 5-1**

Other Diameters on Request

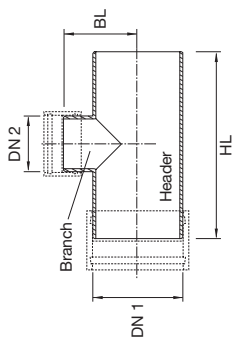

**Segmented Tees**  
**Pressure Class PN 32**  
**DN 2 = 100 – 800 mm**

DN 2 \ DN 1	100		150		200		250		300		350		400		450		500		600		700		800	
	HL	BL	HL	BL	HL	BL	HL	BL	HL	BL	HL	BL	HL	BL	HL	BL	HL	BL	HL	BL	HL	BL	HL	BL
300	820	440	920	460	1020	500	1120	520	1220	620	-	-	-	-	-	-	-	-	-	-	-	-	-	-
350	840	460	940	500	1040	540	1140	560	1240	660	680	1340	-	-	-	-	-	-	-	-	-	-	-	-
400	860	500	940	520	1060	560	1180	600	1280	700	720	1360	1440	720	-	-	-	-	-	-	-	-	-	-
450	860	540	960	560	1080	620	1200	640	1300	740	760	1420	1480	780	800	1560	800	-	-	-	-	-	-	-
500	880	560	1000	600	1080	640	1200	660	1320	780	800	1440	1540	820	840	1620	860	1700	860	-	-	-	-	-
600	980	620	1080	660	1200	700	1300	720	1420	820	860	1520	1620	880	920	1740	940	1820	940	1980	1000	-	-	-
700	1020	700	1120	720	1240	760	1340	800	1460	900	920	1580	1680	960	1000	1800	1020	1880	1080	2060	2220	1120	-	-
800	1060	760	1160	800	1280	840	1380	860	1500	960	1000	1600	1720	1020	1060	1840	1080	1940	1160	2100	2300	1200	1240	1320
900	1100	840	1200	860	1300	900	1420	940	1520	1020	1060	1660	1760	1100	1120	1860	1160	1980	1240	2160	2360	1280	1320	1450
1000	1150	950	1250	950	1350	1000	1500	1000	1600	1100	1150	1700	1800	1200	1200	1900	1250	2050	1300	2200	2450	1400	1450	1500
1100	1200	1000	1300	1000	1400	1050	1500	1100	1650	1200	1250	1750	1850	1250	1300	1950	1300	2050	1400	2250	2500	1450	1500	1600
1200	1250	1050	1350	1100	1450	1100	1550	1150	1700	1250	1300	1750	1900	1300	1350	2000	1400	2100	1450	2300	2550	1500	1550	1650
1300	1300	1150	1400	1150	1500	1200	1600	1250	1700	1350	1350	1800	1950	1400	1400	2050	1450	2150	1450	2350	2550	1600	1650	1700
1400	1350	1200	1450	1250	1550	1250	1650	1300	1750	1400	1450	1850	1950	1450	1500	2050	1500	2200	1500	2350	2600	1650	1700	1700

**Table 7-3-15 Header- and Branch Lengths Segmented Tee Pipe Series in mm – PN 32 – Stiffness Classes acc. to Table 5-1**

Other Diameters on Request

## 7.4 Moulded Bends

The tables below refer to moulded bends up to pressure class PN 16. Moulded bends for higher pressure classes are available on request.

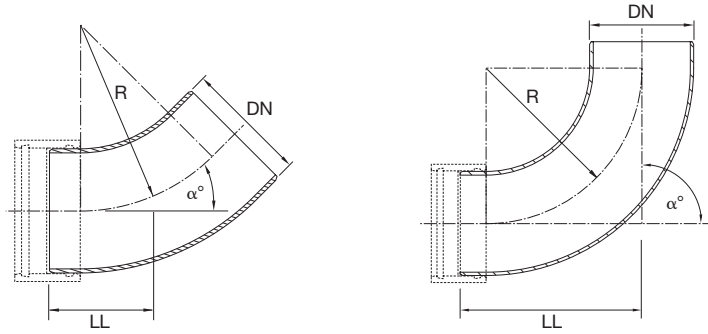

### Pressure Class PN 1 / PN 6

DN [mm]	R [mm]		Angle $\alpha$													
			11°		15°		22°		30°		45°		60°		90°	
			LL min [mm]	Weight* [kg/pc]	LL min [mm]	Weight* [kg/pc]	LL min [mm]	Weight* [kg/pc]	LL min [mm]	Weight* [kg/pc]	LL min [mm]	Weight* [kg/pc]	LL min [mm]	Weight* [kg/pc]	LL min [mm]	Weight* [kg/pc]
100	150.0	+1 -0	94	1.06	100	1.09	109	1.14	120	1.21	142	1.33	167	1.44	230	1.68
150	225.0		102	1.87	110	1.93	124	2.05	140	2.19	173	2.44	210	2.70	305	3.21
200	300.0		122	3.01	132	3.13	151	3.33	173	3.57	217	4.02	266	4.47	393	5.36
250	375.0		130	4.63	143	4.83	167	5.18	194	5.58	249	6.33	311	7.08	469	8.58
300	450.0		184	7.84	200	8.17	228	8.74	262	9.39	327	10.61	401	11.84	591	14.28
350	525.0	+3 -0	193	11.47	211	11.97	244	12.83	283	13.82	359	15.68	445	17.54	667	21.25
400	600.0		199	13.06	220	13.77	258	15.02	302	16.44	390	19.11	487	21.78	741	27.12
500	750.0		213	18.98	240	20.32	287	22.67	342	25.35	452	30.37	574	35.40	891	45.45
600	900.0		259	29.99	290	32.15	347	35.92	413	40.23	545	48.32	692	56.41	1072	72.58
700	1050.0		273	42.49	310	45.93	376	51.95	453	58.82	607	71.72	778	84.61	1222	110.40
800	1200.0		289	52.98	331	57.91	406	66.53	495	76.38	670	94.84	866	113.31	1373	150.25

\* Approx. Weights

Table 7-4-1 Moulded Bends – Stiffness SN 10000 (N/m<sup>2</sup>)

### Pressure Class PN 10

DN [mm]	R [mm]		Angle $\alpha$													
			11°		15°		22°		30°		45°		60°		90°	
			LL min [mm]	Weight* [kg/pc]	LL min [mm]	Weight* [kg/pc]	LL min [mm]	Weight* [kg/pc]	LL min [mm]	Weight* [kg/pc]	LL min [mm]	Weight* [kg/pc]	LL min [mm]	Weight* [kg/pc]	LL min [mm]	Weight* [kg/pc]
100	150.0	+1 -0	94	1.06	100	1.09	109	1.14	120	1.21	142	1.33	167	1.44	230	1.68
150	225.0		102	1.88	110	1.96	124	2.09	140	2.23	173	2.51	210	2.79	305	3.34
200	300.0		122	3.13	132	3.30	151	3.59	173	3.92	217	4.54	266	5.16	393	6.39
250	375.0		130	4.85	143	5.14	167	5.63	194	6.20	249	7.26	311	8.32	469	10.45
300	450.0		184	8.29	200	8.78	228	9.64	262	10.62	327	12.46	401	14.29	591	17.97
350	525.0	+3 -0	193	12.23	211	13.00	244	14.35	283	15.89	359	18.78	445	21.67	667	27.45
400	600.0		199	14.15	220	15.26	258	17.20	302	19.42	390	23.58	487	27.74	741	36.07
500	750.0		213	21.10	240	23.22	287	26.91	342	31.14	452	39.06	574	46.98	891	62.82
600	900.0		259	33.41	290	36.81	347	42.75	413	49.55	545	62.30	692	75.04	1072	100.53
700	1050.0		273	47.99	310	53.43	376	62.94	453	73.82	607	94.21	778	114.61	1222	155.39
800	1200.0		289	61.34	331	69.30	406	83.24	495	99.17	670	129.03	866	158.89	1373	218.62

\* Approx. Weights

Table 7-4-2 Moulded Bends – Stiffness SN 10000 (N/m<sup>2</sup>)

01

02

03

04

05

06

07

08

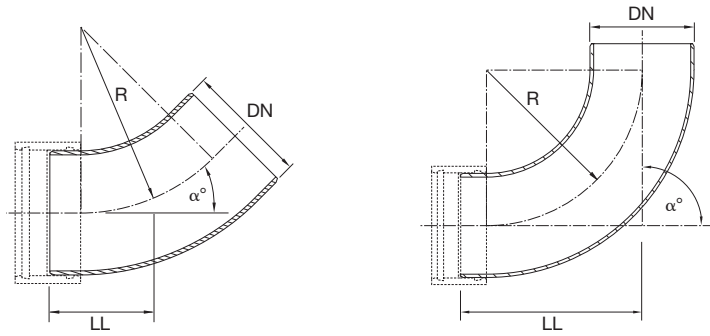

### Pressure Class PN 16

DN [mm]	R [mm]		Angle $\alpha$													
			11°		15°		22°		30°		45°		60°		90°	
			LL min [mm]	Weight* [kg/pc]	LL min [mm]	Weight* [kg/pc]	LL min [mm]	Weight* [kg/pc]	LL min [mm]	Weight* [kg/pc]	LL min [mm]	Weight* [kg/pc]	LL min [mm]	Weight* [kg/pc]	LL min [mm]	Weight* [kg/pc]
100	150.0	+1 -0	94	1.06	100	1.10	109	1.16	120	1.23	142	1.36	167	1.48	230	1.74
150	225.0		102	1.97	110	2.07	124	2.25	140	2.46	173	2.85	210	3.25	305	4.03
200	300.0		122	3.34	132	3.58	151	3.99	173	4.47	217	5.37	266	6.27	393	8.06
250	375.0		130	6.04	143	6.47	167	7.21	194	8.06	249	9.65	311	11.24	469	14.42
300	450.0		184	11.00	200	11.71	228	12.95	262	14.37	327	17.03	401	19.69	591	25.00
350	525.0	+3 -0	193	15.03	211	16.15	244	18.13	283	20.39	359	24.62	445	28.86	667	37.32
400	600.0		199	18.91	220	20.60	258	23.56	302	26.93	390	33.27	487	39.60	741	52.26
500	750.0		213	27.12	240	30.31	287	35.88	342	42.25	452	54.20	574	66.14	891	90.03
600	900.0		259	46.97	290	52.38	347	61.85	413	72.68	545	92.97	692	113.26	1072	153.85
700	1050.0		273	65.68	310	74.16	376	89.00	453	105.96	607	137.76	778	169.56	1222	233.17
800	1200.0	289	87.00	331	99.52	406	121.44	495	146.48	670	193.43	866	240.39	1373	334.30	

\* Approx. Weights

Table 7-4-3 Moulded Bends – Stiffness SN 10000 (N/m<sup>2</sup>)

## 7.5 Moulded Reducers – Concentric –

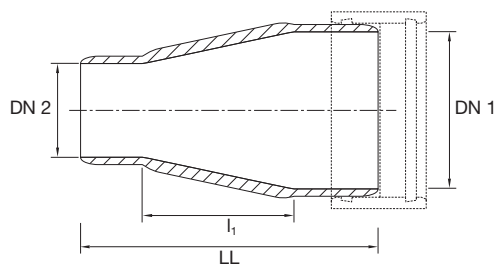

					PN 1 / PN 6	PN 10	PN 16
DN 1	DN 2	$l_1$ [mm]	LL [mm]		Weight* [kg/pc]		
150	100	135.0	315.0	+0	1.72	1.72	1.91
200	100	260.0	453.0	+0 -6	2.88	2.88	3.62
200	150	135.0	328.0		2.72	2.72	3.26
250	150	260.0	454.0		3.87	4.33	5.67
250	200	135.0	342.0		3.81	4.16	5.24
300	200	260.0	514.0		6.21	7.45	9.44
300	250	135.0	390.0		5.73	6.66	8.87
400	250	385.0	640.0		10.73	12.81	17.40
400	300	260.0	562.0		11.28	13.05	17.58
500	300	510.0	812.0		18.45	21.66	30.64
500	400	260.0	562.0		16.65	18.90	25.55
600	400	510.0	843.0	+0 -8	25.20	31.23	45.23
600	500	260.0	593.0		22.54	26.76	37.13
700	500	510.0	843.0		35.00	42.18	61.52
700	600	260.0	624.0		32.63	37.67	52.97
800	600	510.0	875.0		46.66	57.88	84.36
800	700	260.0	625.0		42.67	50.41	69.08

\* Approx. Weights

**Table 7-5 Concentric Reducers – Stiffness SN 10000 (N/m<sup>2</sup>)**

The table above refers to moulded reducers up to pressure class PN 16. Moulded reducers for higher pressure classes are available on request.

## 7.6 Moulded Tees – Equal and Reduced –

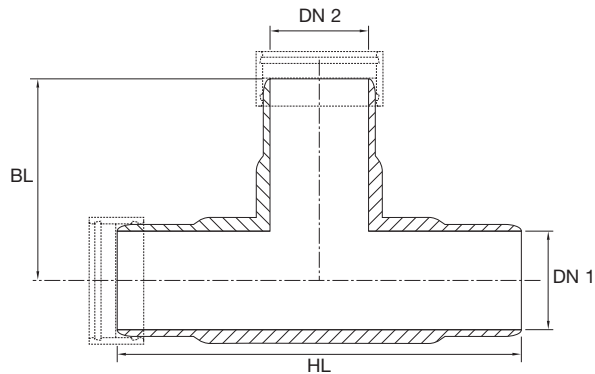

						PN 1 / PN 6	PN 10	PN 16
DN 1	DN 2	HL [mm]		BL [mm]		Weight* [kg/pc]		
100	100	330		165		1.87	1.87	1.87
150	100	370	+0 -4	185	+0 -2	2.97	2.97	3.23
150	150	370		185		3.44	3.44	3.70
200	100	454		215		4.44	4.68	5.49
200	150	454		215		4.83	5.08	5.86
200	200	454		227		5.44	5.70	6.48
250	200	624		312		7.91	9.07	12.15
250	250	624		312		8.46	9.64	13.24
300	200	780		342		11.37	14.16	19.41
300	250	780		342		11.92	14.77	20.45
300	300	780	+0 -6	390	+0 -3	13.27	16.17	22.24
350	300	810		405		16.66	20.13	28.49
350	350	810		405		17.61	21.13	29.90
400	300	860		430		20.28	25.64	35.64
400	400	860		430		22.27	27.75	38.07
500	400	970		485		32.81	42.98	59.78
500	500	970		485		34.60	44.92	62.39
600	500	1130		535		49.82	67.23	94.69
600	600	1130		565		53.10	70.28	97.12
700	600	1230		615		72.82	96.60	138.21
700	700	1230	+0 -8	615	+0 -4	76.80	100.80	141.23
800	700	1330		665		98.86	132.62	192.35
800	800	1330		665		101.82	135.84	195.93

\* Approx. Weights

**Table 7-6 Moulded Tees – Stiffness SN 10000 (N/m<sup>2</sup>)**

The table above refers to moulded tees up to pressure class PN 16. Moulded tees for higher pressure classes are available on request.

# 7.7 Wall Couplings

- 01
- 02
- 03
- 04
- 05
- 06
- 07
- 08

The wall couplings are based on double bell FC couplings acc. to **table 5-4** and **5-6** and compatible to pipes listed in **table 5-3** and **5-5**.

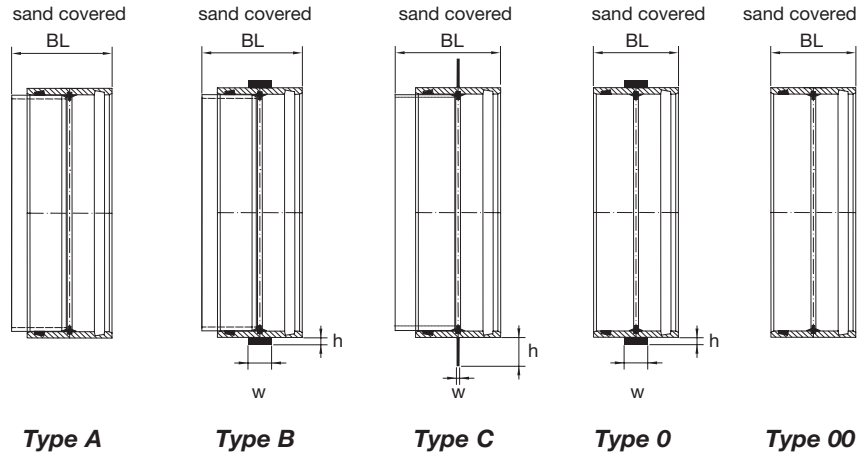

	Type A, B, C	Type B		Type C	
DN [mm]	BL [mm]	w [mm]	h [mm]	w [mm]	h [mm]
100	300	50	11	8	80
150	300	50	11	8	80
200	300	50	16	8	80
250	300	50	16	8	80
300	300	50	21	8	80
350	300	50	21	8	80
400	300	50	21	8	80
450	300	50	21	8	80
500	300	50	21	8	80
600	300	80	24	8	80
700	300	80	24	8	80
800	300	80	24	10	80
900	300	80	24	10	80
1000	300	80	25	12	100
1100	300	80	25	12	100
1200	300	80	25	12	100
1300	300	120	26	15	100
1400	300	120	26	15	100
1500	300	120	26	15	100
1600	300	120	26	15	100
1700	300	120	27	15	100
1800	300	120	27	20	120
1900	300	120	27	20	120
2000	300	120	27	20	120
2100	300	120	27	20	120
2200	300	120	27	20	120
2300	300	120	28	20	120
2400	300	120	28	20	120

Table 7-7-1 Wall Couplings – Type A, B, C

	Type 0, 00	Type 0	
DN [mm]	BL [mm]	w [mm]	h [mm]
100	150	50	11
150	150	50	11
200	175	50	16
250	175	50	16
300	240	50	21
350	240	50	21
400	240	50	21
450	240	50	21
500	240	50	21
600	240	80	24
700	240	80	24
800	240	80	24
900	240	80	24
1000	240	80	25
1100	240	80	25
1200	240	80	25
1300	240	120	26
1400	240	120	26
1500	240	120	26
1600	240	120	26
1700	240	120	27
1800	240	120	27
1900	240	120	27
2000	240	120	27
2100	240	120	27
2200	240	120	27
2300	240	120	28
2400	240	120	28

Table 7-7-2 Wall Couplings – Type 0, 00

## 7.8 Fix Flanges – Type A

The standard bolting pattern to which flanges are manufactured is ISO 2084. Other bolting dimension systems such as AWWA, ANSI, DIN, JIS can be supplied.

The following tables refer to fix flanges up to pressure class PN 16. Fix flanges type A for higher pressure classes are available on request.

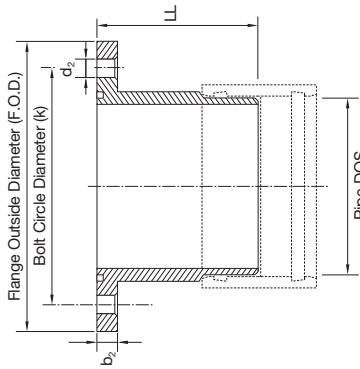

**Pressure Classes PN 1, PN 6 & PN 10**

DN	Pipe DOS	$b_2$	F.O.D.	LL	k	Number of Bolts	Bolt Diameter [mm]	Bolt Hole Diameter [mm]	Washer Diameter [mm]	O-Ring Gasket Diameter [mm]
Nominal Diameter	O.D. [mm]	Flange Thickness [mm]	Flange Outside Diameter [mm]	Laying Length [mm]	Bolt Circle Diameter [mm]					
300	324.5	40	450	1000	400	12	20	26	36	12
350	376.4	45	525	1000	460	16	20	26	36	12
400	427.3	47	575	1000	515	16	24	30	44	12
450	478.2	52	625	1000	565	20	24	30	44	12
500	530.1	53	675	1000	620	20	24	30	44	12
600	617	55	800	1000	725	20	27	33	50	12
700	719	64	900	1000	840	24	27	33	50	19
800	821	69	1025	1000	950	24	30	36	56	19
900	923	74	1125	1000	1050	28	30	36	56	19
1000	1025	79	1250	1000	1160	28	33	39	60	19
1100	1127	88	1350	1000	1270	32	33	39	60	22
1200	1229	94	1475	1000	1380	32	36	42	68	22
1300	1331	97	1575	1000	1490	32	39	45	72	22
1400	1433	104	1700	1000	1590	36	39	45	72	22
1500	1535	107	1800	1000	1700	36	39	45	72	22
1600	1637	114	1925	1000	1820	40	45	51	85	22
The following flanges list the maximum pipe O.D. on which the flange can be fabricated without interference of bolt hole and spot facing with the flange hub.										
1800	1815	128	2125	1000	2020	44	45	51	85	25
2000	2015	139	2350	1000	2230	48	45	51	85	25
2200	2200	153	2575	1000	2440	52	52	58	98	28
2400	2400	164	2775	1000	2650	56	52	58	98	28
2600	2588	176	2975	1000	2850	60	52	58	98	28
2800	2796	186	3200	1000	3070	64	52	58	98	28
3000	2999	197	3425	1000	3290	68	56	62	105	28

**Table 7-8-1 Fix Flanges – Type A – PN 1, PN 6 & PN 10 – for all Stiffness Classes**

Bigger Dimensions on Request

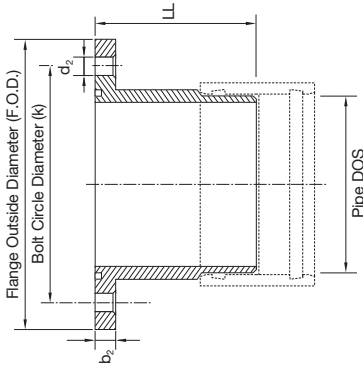

**Pressure Class PN 16**

DN	Pipe DOS	b <sub>2</sub>	F.O.D.	LL	k	Number of Bolts	Bolt Diameter [mm]	d <sub>2</sub>	Washer Diameter [mm]	O-Ring Gasket Diameter [mm]
Nominal Diameter	O.D. [mm]	Flange Thickness [mm]	Flange Outside Diameter [mm]	Laying Length [mm]	Bolt Circle Diameter [mm]			Bolt Hole Diameter [mm]		
300	324	40	475	1000	410	12	24	30	44	12
350	376	45	525	1000	470	16	24	30	44	12
400	427	47	600	1000	525	16	27	33	50	12
450	478	52	650	1000	585	20	27	33	50	12
500	530	53	725	1000	650	20	30	36	56	12
600	617	57	850	1000	770	20	33	39	60	12
700	719	66	925	1000	840	24	33	39	60	19
800	821	72	1050	1000	950	24	36	42	68	19
900	923	78	1150	1000	1050	28	36	42	68	19
1000	1025	83	1275	1000	1170	28	39	45	72	19
The following flanges list the maximum pipe O.D. on which the flange can be fabricated without interference of bolt hole and spot facing with the flange hub.										
1100	1112	93	1375	1000	1270	32	39	45	72	22
1200	1214	98	1500	1000	1390	32	45	51	85	22
1300	1309	104	1600	1000	1490	32	45	51	85	22
1400	1403	110	1700	1000	1590	36	45	51	85	22
1500	1504	115	1825	1000	1710	36	52	58	98	22
1600	1608	121	2050	1000	1820	40	52	58	98	22
1800	1795	136	2150	1000	2020	44	52	58	98	25
2000	1987	147	2350	1000	2230	48	56	62	105	25
2200	2183	162	2575	1000	2440	52	56	62	105	28
2400	2382	174	2775	1000	2650	56	56	62	105	28

**Table 7-8-2 Fix Flanges – Type A – PN 16 – for all Stiffness Classes**

Bigger Dimensions on Request

01

02

03

04

05

06

07

08

## 7.9 Fix Flanges – Type B (laminated on pipe ends)

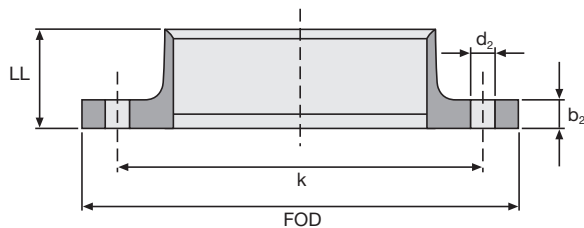

The tables below refer to fix flanges up to pressure class PN 16. Fix flanges Type B for higher pressure classes are available on request.

### Pressure Class PN 1 / PN 6

DN	FOD [mm]		d <sub>2</sub> [mm]	k [mm]		b <sub>2</sub> [mm]		LL [mm]		No. of bolts	Weight* [kg/pc]
100	220	±2	20	170	±1.6	26	±2	45	+5 -0	4	1.68
150	285		20	225		32		65		8	2.72
200	340		20	280		34		125		8	3.72
250	405	±3	20	335	±1.6	38	±2	100	+5 -0	12	5.07
300	460		24	395		40		125		12	6.87
350	520		24	445		45		145		12	8.72
400	580	±5	24	495	±1.9 -0	49	+8 -2	165	+10 -0	16	10.43
500	715		24	600		30		75		20	17.47
600	840		28	705		33		90		20	24.32
700	910	±5	28	810	±1.9 -0	37	+8 -2	105	+10 -0	24	29.33
800	1025		31	920		40		120		24	37.37

\* Approx. Weights

Table 7-9-1 Fix Flanges – Type B – PN 1 / PN 6

Bigger Dimensions on Request

### Pressure Class PN 10

DN	FOD [mm]		d <sub>2</sub> [mm]	k [mm]		b <sub>2</sub> [mm]		LL [mm]		No. of bolts	Weight* [kg/pc]
100	220	±2	20	180	±1.6	26	±2	45	+5 -0	8	1.88
150	285		24	240		32		65		8	3.28
200	340		24	295		34		125		8	4.45
250	405	±3	24	350	±1.6	38	±2	100	+5 -0	12	6.02
300	460		24	400		40		125		12	7.33
350	520		24	460		45		145		16	14.84
400	580	±5	28	515	±1.9 -0	49	+8 -2	165	+10 -0	16	13.38
500	715		28	620		48		125		20	29.80
600	840		31	725		52		150		20	43.40
700	910	±5	31	840	±1.9 -0	56	+8 -2	175	+10 -0	24	49.75
800	1025		34	950		60		200		24	66.57

\* Approx. Weights

Table 7-9-2 Fix Flanges – Type B – PN 10

Bigger Dimensions on Request

**Pressure Class PN 16**

DN	FOD [mm]		d <sub>2</sub> [mm]	k [mm]		b <sub>2</sub> [mm]		LL [mm]		No. of bolts	Weight* [kg/pc]
100	220	±2	20	180	±1.6	26	±2	45	+5 -0	8	1.92
150	285		24	240		32		65		8	3.38
200	340		24	295		34		125		12	5.00
250	405	±3	28	355	±1.6	38	±2	100	+5 -0	12	7.22
300	460		28	410		40		125		12	9.81
350	520		28	470		45		145		16	17.95
400	580		31	525		49		165		16	17.56
500	715	±5	34	650	±1.9 -0	54	+8 -2	200	+10 -0	20	38.78
600	840		37	770		60		240		20	57.95
700	910		37	840		70		280		24	76.90
800	1025		40	950		72		320		24	97.41

\* Approx. Weights

**Table 7-9-3 Fix Flanges – Type B – PN 16**

Bigger Dimensions on Request

## 7.10 Blind Flanges

The standard bolting pattern to which flanges are manufactured is ISO 2084. Other bolting dimension systems such as AWWA, ANSI, DIN, JIS can be supplied.

The tables below refer to blind flanges up to pressure class PN 16. Blind flanges for higher pressure classes are available on request.

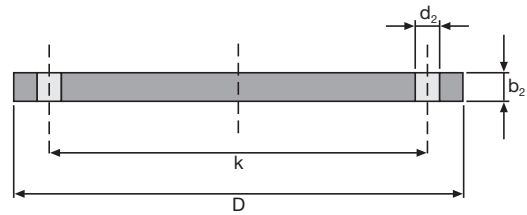

### Pressure Class PN 1 / PN 6

DN	D [mm]		d <sub>2</sub> [mm]	k [mm]		b <sub>2</sub> [mm]		No. of bolts	Weight* [kg/pc]
100	220	±2	20	170	±1,6	26	±2	4	1.39
150	285		20	225		32		8	2.58
200	340		20	280		34		8	3.84
250	405	±3	20	335	±1,6	38	±2	12	5.69
300	460		24	395		40		12	7.30
350	520		24	445		45		12	10.25
400	580	±5	24	495	±1,9 -0	49	±2	16	13.30
500	715		24	600		54		20	21.88
600	840		28	705		60		20	32.55
700	910	±5	28	810	±1,9 -0	70	±2	24	42.49
800	1025		31	920		72		24	57.45

\* Approx. Weights

Table 7-10-1 Blind Flanges – PN 1 / PN 6

### Pressure Class PN 10

DN	D [mm]		d <sub>2</sub> [mm]	k [mm]		b <sub>2</sub> [mm]		No. of bolts	Weight* [kg/pc]
100	220	±2	20	180	±1,6	26	±2	8	1.75
150	285		24	240		32		8	3.62
200	340		24	295		34		8	5.52
250	405	±3	24	350	±1,6	38	±2	12	8.35
300	460		24	400		40		12	11.47
350	520		24	460		45		16	15.55
400	580	±5	28	515	±1,9 -0	49	±2	16	20.46
500	715		28	620		54		20	36.30
600	840		31	725		60		20	49.89
700	910	±5	31	840	±1,9 -0	70	±2	24	62.80
800	1025		34	950		72		24	84.99

\* Approx. Weights

Table 7-10-2 Blind Flanges – PN 10

**Pressure Class PN 16**

DN	D [mm]		d <sub>2</sub> [mm]	k [mm]		b <sub>2</sub> [mm]		No. of bolts	Weight* [kg/pc]
100	220	±2	20	180	±1,6	26	±2	8	1.93
150	285		24	240		32		8	3.77
200	340		24	295		34		12	5.73
250	405	±3	28	355	±1,6	38	±2	12	8.94
300	460		28	410		40		12	11.85
350	520		28	470		45		16	16.99
400	580	±5	31	525	±1,9 -0	49	±2	16	22.85
500	715		34	650		54		20	37.20
600	840		37	770		60		20	57.32
700	910	±5	37	840	±1,9 -0	70	±2	24	77.31
800	1025		40	950		72		24	101.52

\* Approx. Weights

**Table 7-10-3 Blind Flanges – PN 16**

## 7.11 Loose Flanges and Collars

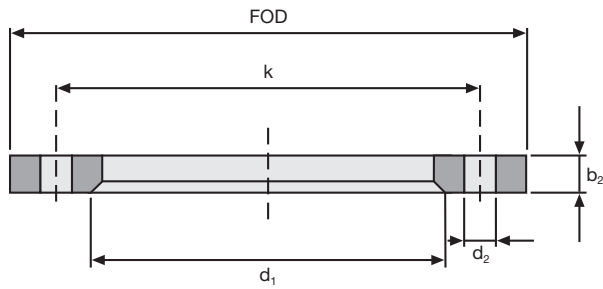

**Loose Flange**

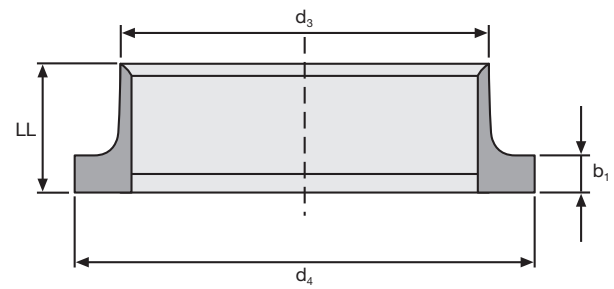

**Moulded Collar**

The following tables refer to flanges and collars up to pressure class PN 16. Flanges and collars for higher pressure classes are available on request.

### Pressure Class PN 1 / PN 6

DN	FOD [mm]	d <sub>1</sub> [mm]	d <sub>2</sub> [mm]	d <sub>3</sub> [mm]	d <sub>4</sub> [mm]	k [mm]	b <sub>1</sub> [mm]	b <sub>2</sub> [mm]	LL [mm]	No. of bolts	Weight* [kg/pc]									
											Collar	Flange	Total							
100	220	±2	134	20	133	±1	148	+0.5 -0	170	±1.6	26	±2	26	±2	45	+5 -0	4	1.68	0.84	2.52
150	285	±2	189	20	188	±1	201	+0.5 -0	225	±1.6	32	±2	32	±2	65	+5 -0	8	2.72	1.41	4.12
200	340	±2	238	20	237	±1	257	+0.5 -0	280	±1.6	34	±2	34	±2	125	+5 -0	8	3.72	1.91	5.63
250	405	±2	294	20	292	±1	309	+0.5 -0	335	±1.6	38	±2	38	±2	100	+5 -0	12	5.07	2.64	7.70
300	460	±2	344	24	342	±1	365	+1 -0	395	±1.6	40	±2	40	±2	125	+5 -0	12	6.87	3.16	10.03
350	520	±3	388	24	386	±2	415	+1 -0	445	±1.6	45	±2	45	±2	145	+5 -0	12	8.63	4.47	13.10
400	580	±2	442	24	440	±2	466	+1 -0	495	±1.6	49	±2	49	±2	165	+5 -0	16	10.43	5.49	15.92

\* Approx. Weights

**Table 7-11-1 Loose Ring Flanges incl. Collar – PN 1 / PN 6**

Other Diameters up to DN 1600 on Request

### Pressure Class PN 10

DN	FOD [mm]	d <sub>1</sub> [mm]	d <sub>2</sub> [mm]	d <sub>3</sub> [mm]	d <sub>4</sub> [mm]	k [mm]	b <sub>1</sub> [mm]	b <sub>2</sub> [mm]	LL [mm]	No. of bolts	Weight* [kg/pc]									
											Collar	Flange	Total							
100	220	±2	134	20	133	±1	158	+0.5 -0	180	±1.6	26	±2	26	±2	45	+5 -0	8	1.88	1.06	2.94
150	285	±2	189	24	188	±1	212	+0.5 -0	240	±1.6	32	±2	32	±2	65	+5 -0	8	3.28	1.97	5.26
200	340	±2	238	24	237	±1	268	+0.5 -0	295	±1.6	34	±2	34	±2	125	+5 -0	8	4.45	2.75	7.20
250	405	±2	294	20	292	±1	320	+0.5 -0	350	±1.6	38	±2	38	±2	100	+5 -0	12	6.02	3.87	9.89
300	460	±2	344	24	342	±1	370	+1 -0	400	±1.6	40	±2	40	±2	125	+5 -0	12	7.33	4.96	12.29
350	520	±3	388	24	386	±2	430	+1 -0	460	±1.6	45	±2	45	±2	145	+5 -0	16	10.48	6.78	17.26
400	580	±2	442	28	440	±2	482	+1 -0	515	±1.6	49	±2	49	±2	165	+5 -0	16	13.38	8.45	21.83

\* Approx. Weights

**Table 7-11-2 Loose Ring Flanges incl. Collar – PN 10**

Other Diameters up to DN 1600 on Request

**Pressure Class PN 16**

DN	FOD [mm]	d <sub>1</sub> [mm]	d <sub>2</sub> [mm]	d <sub>3</sub> [mm]	d <sub>4</sub> [mm]	k [mm]	b <sub>1</sub> [mm]	b <sub>2</sub> [mm]	LL [mm]	No. of bolts	Weight* [kg/pc]									
											Collar	Flange	Total							
100	220	±2	134	20	133	±1	158	+0.5 -0	180	±1.6	26	±2	26	±2	45	+5 -0	8	1.92	1.17	3.09
150	285		189	24	188		212	240	32		32		65		8		3.38	2.06	5.43	
200	340	±3	238	24	237	±2	268	+1 -0	295	±1.6	34	±2	34	±2	125	+5 -0	12	5.00	2.85	7.85
250	405		294	28	292		321		355		38		38		100		12	7.22	4.14	11.36
300	460	±3	344	28	342	±2	376	+1 -0	410	±1.6	40	±2	40	±2	125	+5 -0	12	9.81	5.13	14.94
350	520		388	28	386		436		470		45		45		145		16	12.96	7.41	20.37
400	580	±3	442	31	440	±2	488	+1 -0	525	±1.6	49	±2	49	±2	165	+5 -0	16	17.56	9.44	27.00

\* Approx. Weights

**Table 7-11-3 Loose Ring Flanges incl. Collar – PN 16**

Other Diameters up to DN 1600 on Request

## 7.12 Wall Connection Pieces Type E

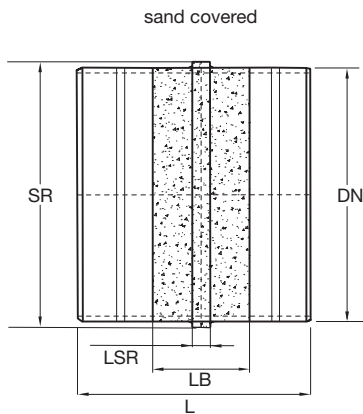

DN [mm]	SR	LSR	LB	L
100	125	50	300	1000
150	200	50	300	1000
200	250	50	300	1000
250	300	50	300	1000
300	350	50	300	1000
350	400	50	300	1000
400	450	50	300	1000
450	500	50	300	1000
500	600	50	300	1000
600	700	80	300	1000
700	800	80	300	1000
800	900	80	300	1000
900	1000	80	300	1000
1000	1100	80	300	1000
1100	1200	80	300	1000
1200	1300	80	300	1500
1300	1400	120	300	1500
1400	1500	120	300	1500
1500	1600	120	300	1500
1600	1700	120	300	1500
1700	1800	120	300	1500
1800	1900	120	300	1500
1900	2000	120	300	1500
2000	2100	120	300	1500
2100	2200	120	300	1500
2200	2300	120	300	1500
2300	2400	120	300	1500
2400	2400	120	300	1500

**Table 7-12 Connection Pieces Type E – Stiffness and Pressure Classes acc. to Tables 5-1 and 5-2**

Bigger Dimensions on Request

## 7.13 Wall Connection Pieces Type F

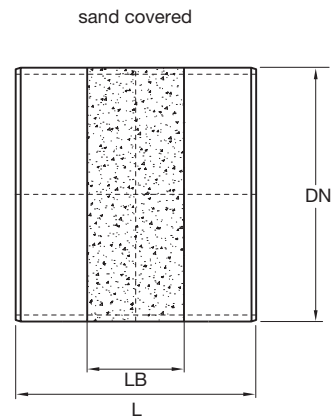

DN [mm]	LB	L
100	300	1000
150	300	1000
200	300	1000
250	300	1000
300	300	1000
350	300	1000
400	300	1000
450	300	1000
500	300	1000
600	300	1000
700	300	1000
800	300	1000
900	300	1000
1000	300	1000
1100	300	1000
1200	300	1500
1300	300	1500
1400	300	1500
1500	300	1500
1600	300	1500
1700	300	1500
1800	300	1500
1900	300	1500
2000	300	1500
2100	300	1500
2200	300	1500
2300	300	1500
2400	300	1500

**Table 7-13 Connection Pieces Type F – Stiffness and Pressure Classes acc. to Tables 5-1 and 5-2**

Bigger Dimensions on Request

## 7.14 Wall Connection Pieces Type G

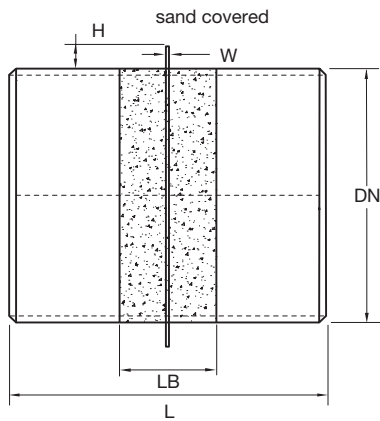

DN [mm]	h	w	LB	L
100	80	8	300	1000
150	80	8	300	1000
200	80	8	300	1000
250	80	8	300	1000
300	80	8	300	1000
350	80	8	300	1000
400	80	8	300	1000
450	80	8	300	1000
500	80	8	300	1000
600	80	8	300	1000
700	80	8	300	1000
800	80	10	300	1000
900	80	10	300	1000
1000	100	12	300	1000
1100	100	12	300	1000
1200	100	12	300	1500
1300	100	15	300	1500
1400	100	15	300	1500
1500	100	15	300	1500
1600	100	15	300	1500
1700	100	15	300	1500
1800	120	20	300	1500
1900	120	20	300	1500
2000	120	20	300	1500
2100	120	20	300	1500
2200	120	20	300	1500
2300	120	20	300	1500
2400	120	20	300	1500

**Table 7-14 Connection Pieces Type G – Stiffness and Pressure Classes acc. to Tables 5-1 and 5-2**

Bigger Dimensions on Request

## 7.15 Short Section Pipes – as connection pieces for valve chambers –

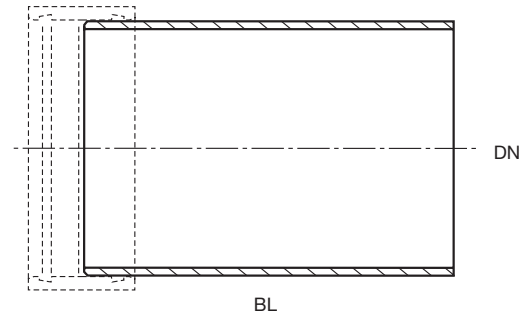

DN [mm]	BL [mm]
100	500
150	500
200	500
250	500
300	500
350	500
400	500
450	500
500	500
600	500
700	750
800	750
900	750
1000	750
1100	750
1200	1000
1300	1000
1400	1000
1500	1000
1600	1000
1700	1000
1800	1000
1900	1000
2000	1000
2100	1000
2200	1000
2300	1000
2400	1000

**Table 7-15 Short Section Pipe – Stiffness and Pressure Classes acc. to Tables 5-1 and 5-2**

Bigger Dimensions on Request

01

02

03

04

05

06

07

08

## 7.16 Valve Chambers

Most pressure pipelines periodically have in-line valves for isolating a portion of the supply or distribution system, air and vacuum relief valves at high points in the pipeline to slowly release accumulated air thereby avoiding blockages or to allow air to enter in order to avoid under pressure, and clean out (wash out) or drainage chambers. All of these different appurtenances can be accommodated with FLOWTITE valve chambers. The ultimate responsibility for the design of the piping systems is the professional engineer. However over the years FLOWTITE Technology engineers have observed many different methods of incorporation these appurtenances into a pipeline using FLOWTITE pipe.

Below are some examples, detailed information is available in the "Installation Guide for Buried Pipes".

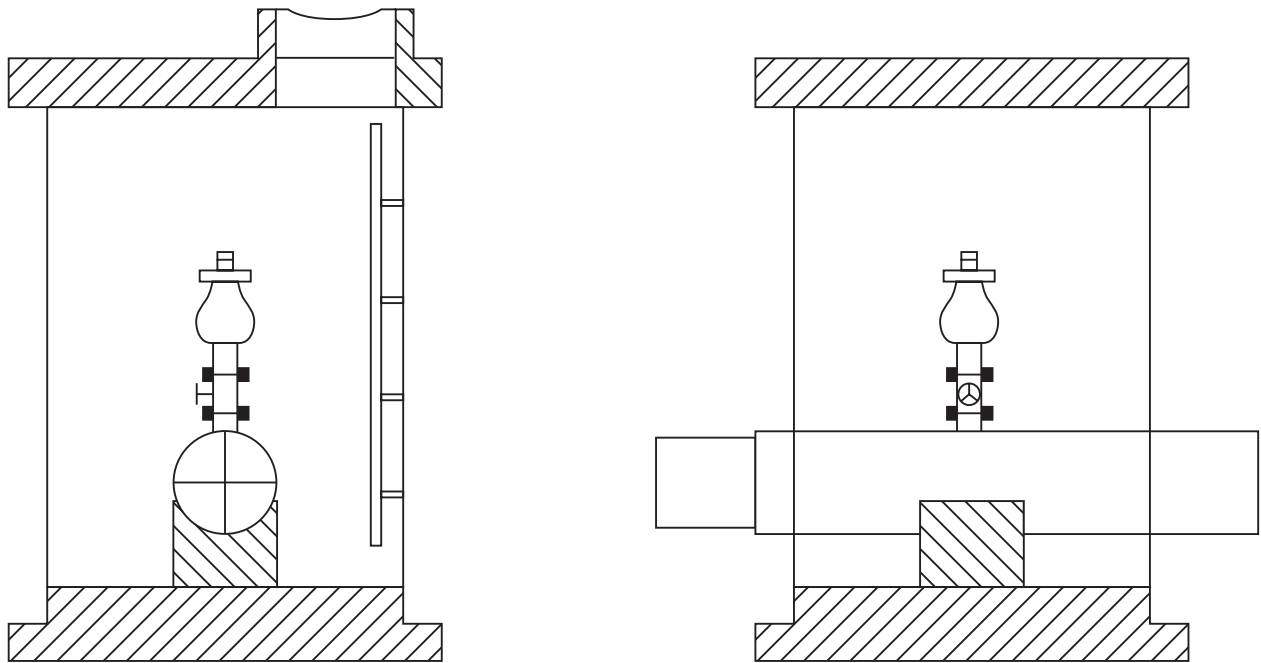

**Figure 7-16 Valve Chambers**

# 8 Local Approvals and Certificates

01

02

03

04

05

06

07

08

This handbook is intended as a guide only. All values listed in the product specifications are nominal. Unsatisfactory product results may occur due to environmental fluctuations, variations in operating procedures, or interpolation of data. We highly recommend that any personnel using this data have specialised training and experience in the application of these products and their normal installation and operating conditions.

The engineering staff should always be consulted before any of these products are installed to ensure the suitability of the products for their intended purpose and applications. We hereby state that we do not accept any liability, and will not be held liable, for any losses or damage which may result from the installation or use of any products listed in this handbook as we have not determined the degree of care required for product installation or service. We reserve the right to revise this data, as necessary, without notice. We welcome comments regarding this handbook.



■

■

**Flowtite Technology AS**

P.O. Box 2059  
3202 Sandefjord  
Norway  
Tel.: + 47 33 44 92 80  
Fax: + 47 33 46 26 17  
info@amiantit.com  
www.flowtite.com  
www.amiantit.com

■

Distributed by: ■